

CLEAN SOIL

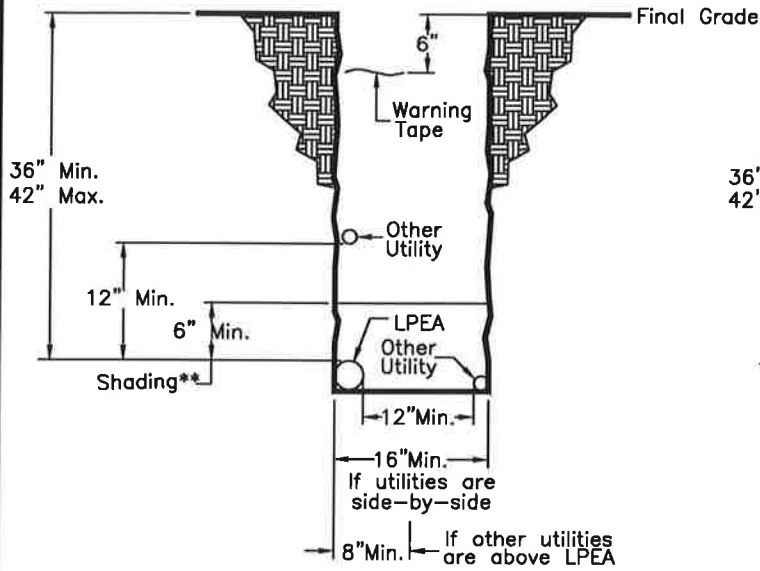

ROCKY SOIL

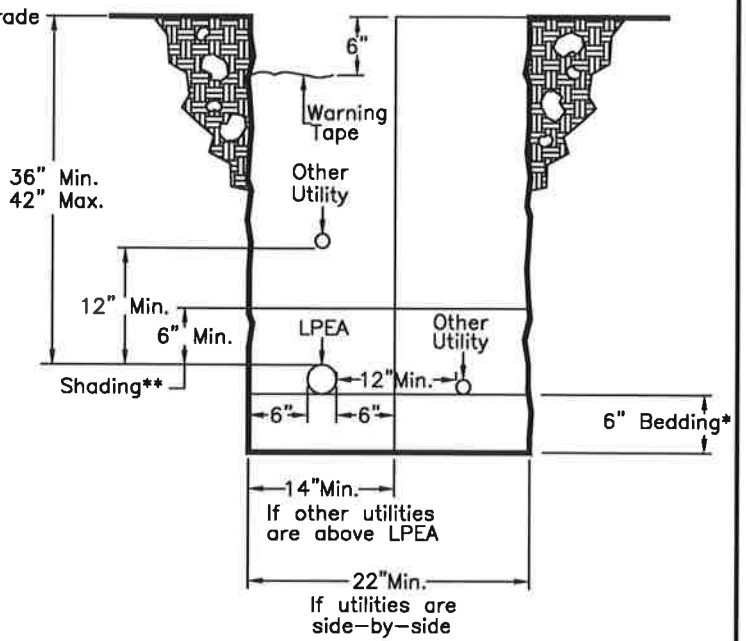

SOLID ROCK

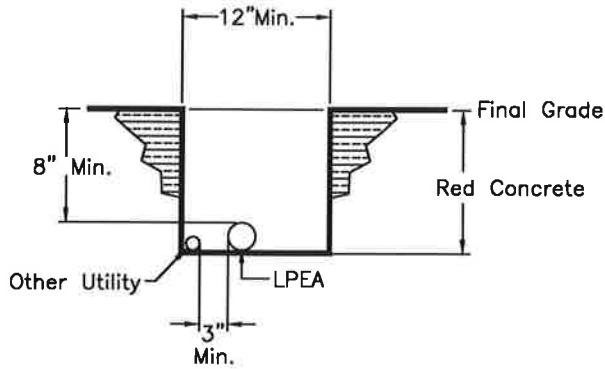

IRRIGATION DITCH

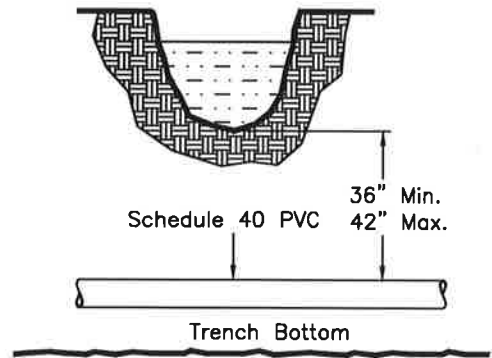

NOTES:

- 3" GREY SCHEDULE 40 PVC SLEEVE REQUIRED ON ALL SINGLE PHASE ROAD CUTS.
- 6" GREY SCHEDULE 40 PVC SLEEVE REQUIRED ON ALL THREE PHASE ROAD CUTS.
- 6" HDPE PIPE WILL BE UTILIZED FOR ALL BORES

WARNING TAPE SUPPLIED BY LPEA; INSTALLED BY CUSTOMER.

* BEDDING (ROCK FREE DIRT OR SAND) TO BE SUPPLIED AND INSTALLED BY CUSTOMER.

** SHADING (ROCK FREE DIRT OR SAND) TO BE SUPPLIED BY CUSTOMER; INSTALLED BY LPEA CREW. SHADING MUST BE SUPPLIED IN 20' INCREMENTS ALONG THE DITCH.

NO.	DATE	REVISIONS	APP'D	DRAWN JDD	UG TRENCH AND BEDDING SPECIFICATIONS	
1	2/27/24		RMW			
				APPROVED	SCALE	DRAWING NUMBER
				DATE 06/26/08	NONE	SPEC 1
				FILE NAME SPEC1.dwg		

LPEA

La Plata Electric Association, Inc.
A Touchstone Energy Cooperative

PO Box 2750
Durango CO 81302-2750
COLORADO 32 LaPLATA

CLEAN SOIL

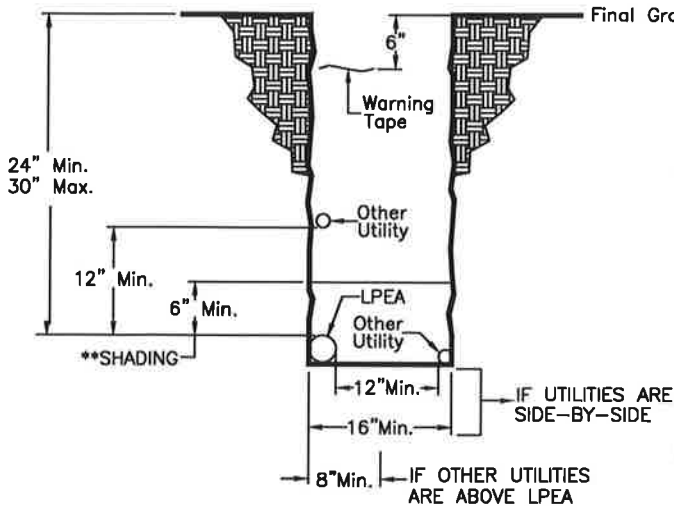

ROCKY SOIL

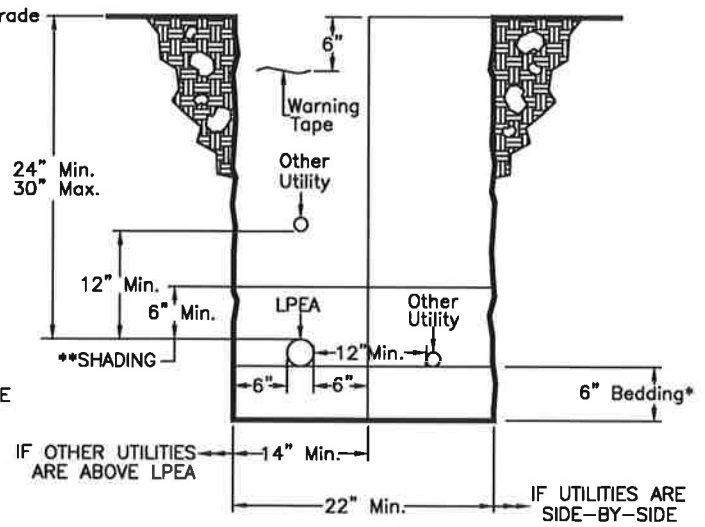

SOLID ROCK

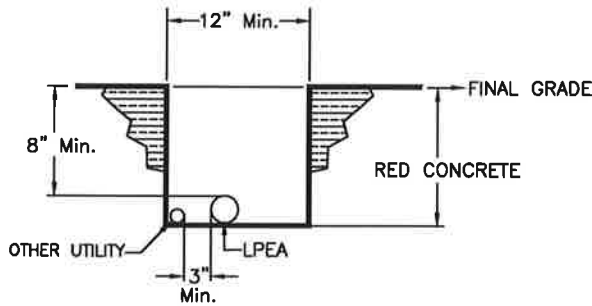

IRRIGATION DITCH

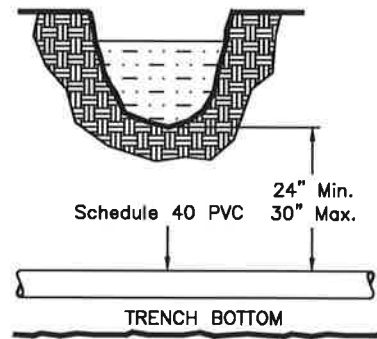

NOTES:

- 3" GREY SCHEDULE 40 PVC SLEEVE REQUIRED ON ALL SINGLE PHASE ROAD CUTS.
- 3" HDPE PIPE WILL BE UTILIZED FOR ALL SINGLE PHASE BORES
- 6" GREY SCHEDULE 40 PVC SLEEVE REQUIRED ON ALL THREE PHASE ROAD CUTS.
- 6" HDPE PIPE WILL BE UTILIZED FOR ALL THREE PHASE BORES

FLOW FILL NOT ACCEPTED.

WARNING TAPE SUPPLIED BY LPEA; INSTALLED BY CUSTOMER.

SERVICES 400 AMP OR GREATER REQUIRE CONSULTATION WITH A STAKING ENGINEER REGARDING SECONDARY REQUIREMENTS.

SERVICES GREATER THAN 800 AMP WILL REQUIRE PARALLEL RUNS OF CONDUIT OF ADEQUATE SIZE FOR THE REQUIRED CONDUCTOR. CUSTOMER MUST CONSULT WITH STAKING ENGINEER.

- * BEDDING (ROCK FREE DIRT OR SAND) TO BE SUPPLIED AND INSTALLED BY CUSTOMER.
- ** SHADING (ROCK FREE DIRT OR SAND) TO BE SUPPLIED BY CUSTOMER; INSTALLED BY LPEA CREW.
- ** SHADING MUST BE SUPPLIED IN 20' INCREMENTS ALONG THE DITCH.

NO.	DATE	REVISIONS	APP'D
1	4/24/21	Removed suggested secondary wire type table	MAF
2	4/24/21	Corrected HDPE sizes on bores	MAF
3	4/24/21	Added required engineer consultation for services of 400 amps or greater	MAF
4	2/27/24		RMW

LPEA
 La Plata Electric Association, Inc.
 A Touchstone Energy Cooperative 
 PO Box 2750
 Durango CO 81302-2750
 COLORADO 32 LaPLATA

DRAWN	JDD
CHECKED	
APPROVED	
DATE	06/26/08
FILE NAME	SPEC2.dwg

UG TRENCH AND BEDDING SPECIFICATIONS	
SECONDARY	
SCALE NONE	DRAWING NUMBER SPEC 2

8" - 17" TRENCH DEPTH

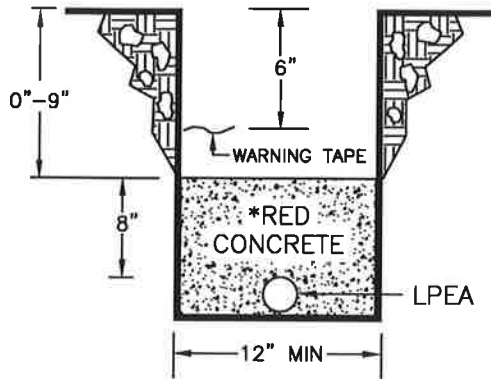

18" - 23" TRENCH DEPTH

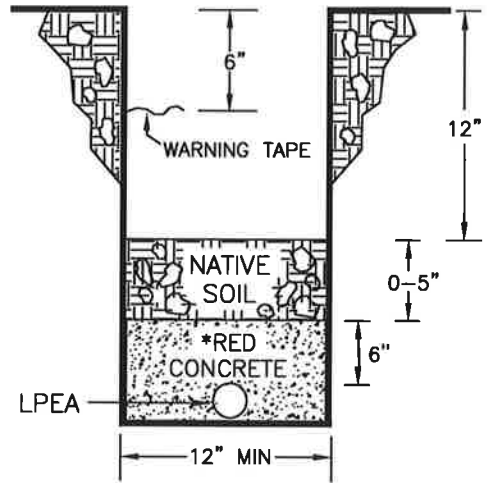

30"-35" TRENCH DEPTH

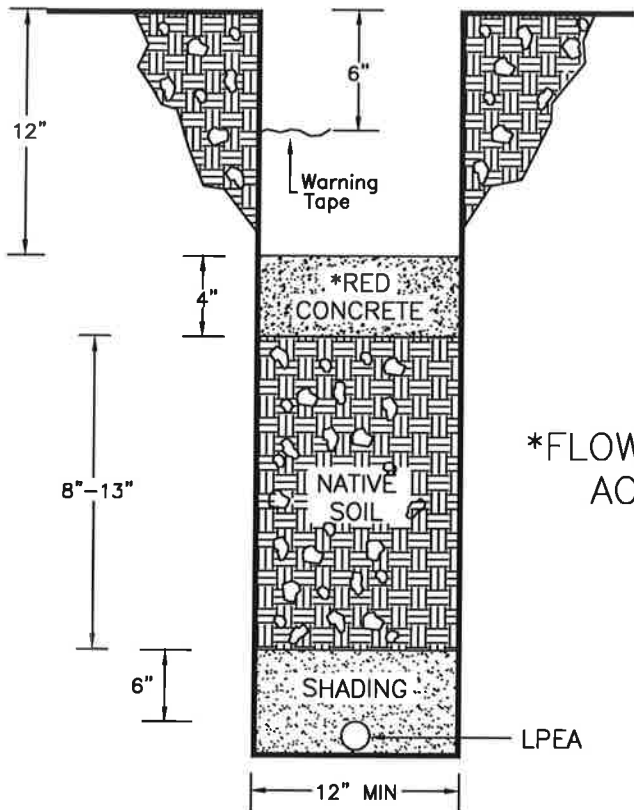

24"-29" TRENCH DEPTH

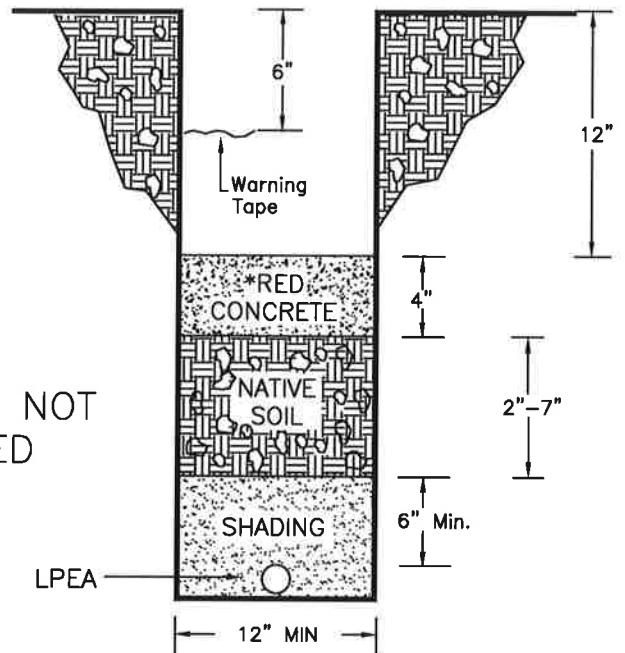

*FLOW FILL NOT ACCEPTED

NO.	DATE	REVISIONS	APP'D
1	2/27/24		RMW

LPEA

La Plata Electric Association, Inc.

A Touchstone Energy Cooperative

PO Box 2750
Durango CO 81302-2750
COLORADO 32 LaPLATA

DRAWN

MF

CHECKED

APPROVED

DATE

06/30/08

FILE NAME

SPEC3.dwg

UG TRENCH SHALLOW DEPTH

PRIMARY / SECONDARY

SCALE
NONE

DRAWING NUMBER
SPEC 3

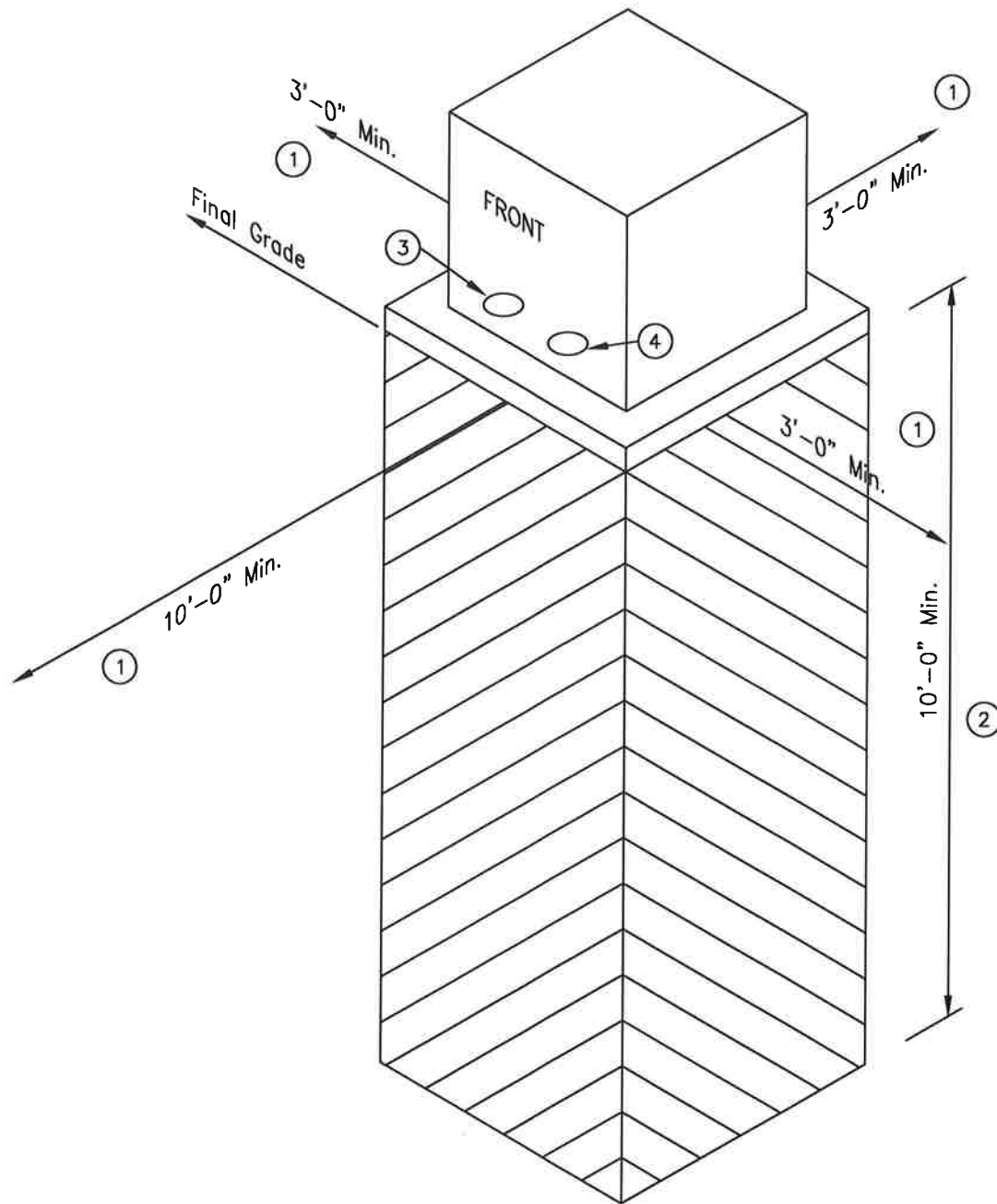

Notes:

- ① Distance required for access. No permanent structures or fences allowed in this area and 4ft from fire hydrants
- ② No other utilities allowed in the defined area under the equipment
- ③ Approximate location of primary conduit
- ④ Approximate location of secondary conduit

NO.	DATE	REVISIONS	APP'D
1	2/27/24	Removed suggested secondary wire type table	RMW

LPEA
 La Plata Electric Association, Inc.
 A Touchstone Energy Cooperative 
 PO Box 2750
 Durango CO 81302-2750
 COLORADO 32 LaPLATA

DRAWN RPC
CHECKED
APPROVED
DATE 02/27/24
FILE NAME SPEC4.dwg

**PAD MOUNT
 UG EQUIPMENT
 SPECIFICATION**

SCALE NONE	DRAWING NUMBER SPEC 4
---------------	--------------------------

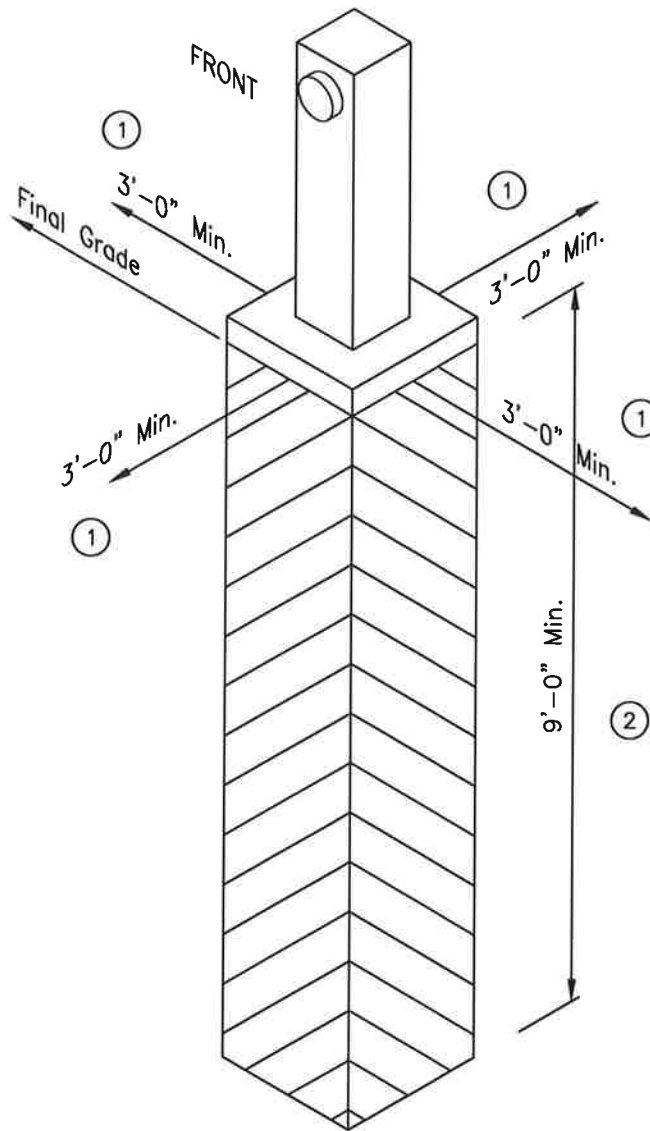

Notes:

- ① Distance required for access. No permanent structures or fences allowed in this area and 4ft from fire hydrants
- ② No other utilities allowed in the defined area under the equipment

NO.	DATE	REVISIONS	APP'D	DRAWN	PEDESTAL SPECIFICATION	
1	2/27/24		RMW	RPC		
				CHECKED		
				APPROVED		
				DATE 02/27/24		
				FILE NAME SPEC5.dwg	SCALE NONE	DRAWING NUMBER SPEC 5

LPEA
 La Plata Electric Association, Inc.
 A Touchstone Energy Cooperative 
 PO Box 2750
 Durango CO 81302-2750
 COLORADO 32 LaPLATA