



Developer/Subdivision

Durango Office:
P.O. Box 2750, Durango, CO 81302
45 Stewart St, Durango, CO 81303
Phone: (970) 247-5786

Pagosa Springs Office:
P.O. Box 305, Pagosa Springs, CO 81147
603 S 8th St, Pagosa Springs, CO 81147
Phone: (970) 247-5786

Developer/Subdivision Work Order

Below is a checklist to assist you with your new construction project:

In order to expedite the assignment of your job to a staking engineer, complete the following:

- Complete and sign the "Application for Work Order" with accurate Service Address (assigned by the county)
 - Complete the "Load Data Sheet", which contains crucial information to ensure an appropriately designed electric service.
(if you need assistance filling out this form, consult with your electrician)
 - Provide the most current recorded copy of Warranty Deed. Name on Warranty Deed must match the name on application for work order.
 - Complete and submit Statement of Authority. Statement of Authority must be signed by the same person signing the application.
 - Pay the required Design Fee (Credit card payments are not accepted for New Construction) \$500 per lot/unit, up to max of \$5,000
- Submit the above by mail or at the office in Durango or Pagosa Springs.

Upon receipt of the above, the first available staking engineer will contact you to arrange an appointment to meet at the site to discuss your job. Please make sure property pins are in place or property boundaries are marked prior to this meeting. After the on-site meeting, the staking engineer will draw your job, compute the construction estimate, and contact you.

(NOTE: The estimate you receive is good for 30 days.)

Job will be released to construction for scheduling after the following are completed:

- Sign and notarize necessary easements and contracts
- Pay construction estimate (credit card payments are not accepted)
- Contact LPEA at (970) 247-5786 and ask to speak with the Line Superintendent, in Durango (La Plata County) or Pagosa Springs (Archuleta County), to coordinate scheduling for construction before you start trenching or clearing right-of-way. Be sure to reference your LPEA Work Order Number when you call.
- Clear right-of-way as required.

For Underground Line Extensions

Prior to digging trench, obtain:

- Existing underground utility locations with the Utility Notification Center of Colorado at (800) 922-1987 or 811
- Any required excavation permits
- Verify that trench location will be within dedicated right-of-way
- Dig your trench. All trenching must be per LPEA specifications. **(A \$600 fee will be charged to the customer if LPEA construction crews show up at the job site and the trench is not ready or if trench does not meet NESC depth specifications.)**

Notify the LPEA Line Superintendent that you are ready for construction to proceed.

LPEA extends line and installs electrical facilities to metering point. **You are responsible for everything past the metering point.**

Contact Colorado State Electrical Inspector to inspect your service; www.dora.state.co.us/electric

Contact LPEA to have your meter installed after:

- Trench has been backfilled (if underground electrical facilities are installed)**
- Your service has been inspected and green-tagged by the Colorado State Electrical Inspector
- Call La Plata Electric at 970-247-5786 with permit # from Colorado Electrical Inspector
- LPEA will energize line and meter

LA PLATA ELECTRIC ASSOCIATION, INC.

Application for Work Order | *Developer-Subdivision*

Revised 1/6/2025

Developer: _____	Project Name: _____
Service Address: _____	Tax ID#: _____
Subdivision: _____	City: _____
Billing Address: _____	# of Lots: _____ Lot #: _____
Home Phone: _____ Cell Phone: _____	City/State: _____ Zip: _____
Project Contact Name: _____	Work Phone: : _____
Project Contact Phone: _____	Email: _____

The undersigned (hereinafter called the "Applicant") hereby applies for and agrees to purchase electric energy from the La Plata Electric Association, Inc. (hereinafter called the "Association") upon the following terms and conditions:

1. The Applicant will comply with and be bound by the provisions of the Articles of Incorporation and Bylaws of the Association, and such rules, regulations, and policies as may periodically be adopted by the Board of Directors of the Association.
2. The Applicant agrees, when electric service is available to these premises, to pay the monthly charge in accordance with the applicable rate schedule. Applicant understands and agrees that the Association's responsibility does not extend beyond the point of the Applicant's ownership of the Applicant's service wires with the exception of the electric meter or pre-pay metering and associated equipment.
3. The Applicant hereby agrees to support and assist the Association in obtaining the right, privilege and easement to construct, operate and maintain the necessary electric facilities together with full right of ingress and egress, as may be necessary to extend and maintain this service. If the Association must purchase or condemn right-of-way, it will do so at the sole expense of the Applicant. The Applicant agrees it shall be solely responsible for the Association's actual expenses for: the acquisition, purchase or condemnation of right-of-way; surveying; special archaeological or environmental studies and permitting; the expenses associated with the construction of roads and reclamation of land damage. The Applicant shall pay to the Association such estimate of costs prior to the Association's commencement of construction. No portion of such payment of expenses is refundable to the Applicant. Any necessary subsequent costs related to permitting and/or renewals or extensions of rights-of-way shall be borne solely by the Applicant, his/her/its heirs, successors or assigns.
4. The Applicant hereby also grants the Association the right to cut and trim trees and shrubbery to the extent necessary to keep them clear of the electric facilities. All boring and trenching provided by the Applicant for the installation of the underground system must be located within the dedicated easements and the Applicant hereby warrants that the location of all required boring and trenching provided by the Applicant so conforms. Any boring and trenching found now, or in the future, outside of the dedicated easement will be relocated within the dedicated easements, and all costs for the relocation will be the responsibility of the Applicant.
5. Upon mutual acceptance, this application for electric service shall constitute a valid binding agreement between Applicant and the Association and shall continue in force until canceled by the Applicant with at least a twenty-four hour prior written notice, which must be received by the Association during regular office hours. This agreement may be terminated by the Association for any reason authorized by the Association's Bylaws or for a material breach of this agreement, including failure of the Applicant to comply with the rules, regulations and bylaws of the Association. The Applicant will remain liable for all charges incurred for electric service herein until the Association is advised of a change in the service.
6. The Applicant agrees to pay a deposit with the Association, such service security deposit as is required by the rules and regulations of the Association. The Applicant hereby grants and Association takes a security interest in said deposit as collateral for service to be applied by the Association, upon any non-payment, termination of service, insolvency, or petition for bankruptcy by undersigned Applicant. The Association shall apply said deposit to bills due the Association and refund any unused portion of deposit upon termination of electric service to the Applicant.
7. If this agreement is for the installation of new service it should be noted that, if this agreement is cancelled subsequent to design and engineering, but prior to construction and connection of new electric service, the Applicant shall be held liable for all costs incurred by the Association in the performance of such activities. It should be further noted that, new electric service and temporary construction service under this agreement are available without actual connection for only one (1) year, thus Applicant should plan to have permanent wiring completed and must request actual connection within that year, or this agreement will terminate and Applicant shall pay the Association for any outstanding service charges arising from this agreement.
8. The Association will schedule construction projects with the Applicant for a specific date upon request by the Applicant or their representative. Any cost overrun attributable to delays or changes caused by the Applicant or their representative will be the responsibility of the Applicant. If your trench will not be ready on the agreed date, you must notify the Association's construction supervisory personnel on or before 7a.m. of the agreed date. If the Association's construction crews show up and, for reasons attributable to a failure of the Applicant or their representative, cannot perform required construction, a \$600 fee will be charged to the Applicant.
9. Unless Applicant also signs the Disclaimer of Membership below, this Application shall constitute an application for membership in the Association. As a member of the Association, Applicant assumes no personal liability or responsibility for any debts or liabilities of the Association, and it is expressly understood that Applicant's private property cannot be attached for any such debts or liabilities of the Association. As a member of the Association, the Applicant agrees to comply with and be bound by the provisions of the Articles of Incorporation and Bylaws of the Association, as the same may periodically be lawfully amended. Each member of the Association, or in the case of a joint membership, the holders thereof jointly, or any one of them, but not all, shall be entitled to one (1) vote and no more upon each matter submitted to a vote of the Association's members.

Applicant

Date

DISCLAIMER OF MEMBERSHIP (OPTIONAL)

The undersigned hereby chooses **not** to become a member of La Plata Electric Association, Inc.

As a customer of the Association, the Applicant agrees to comply with and be bound by the provisions of the Articles of Incorporation and Bylaws, as the same may periodically be lawfully amended.

Primary Applicant

Applicant

Date: _____

Applicant



Durango Office:
P.O. Box 2750, Durango, CO 81302
45 Stewart St, Durango, CO 81303
Phone: (970) 247-5786
Pagosa Springs Office:
P.O. Box 305, Pagosa Springs, CO 81147
603 S 8th St, Pagosa Springs, CO 81147
Phone: (970) 247-5786

Load Data Sheet for Development

Service Location: _____ City: _____
Developer: _____ Phone: _____
Electrician/Contractor: _____ Phone: _____
Project Contact: _____ Phone: _____

1. Processing of this form will not be possible if information is incomplete.
2. Significant revision to information on this form may necessitate rescheduling of job.
3. Any costs incurred by changes to design caused by a change in service requirements after construction is started may be charged to the member.

DISTRIBUTIVE GENERATION

Renewables such as PV, Micro-Hydro, Wind _____ **Total Proposed Generation** _____ kW

ELECTRIC LOAD INFORMATION *(required fields)*

Main Disconnect Size _____ Amps _____ Volts _____ Phase
of Lots/Units: _____

Connected Load

Lighting @ .003 kW/Sq.Ft. _____ kW

Electric Appliances: (Please check all that apply) _____ kW

Range Water Heater
 Oven
 Dryer

Heating and Air Conditioning:

Electric Heat (Non-ETS) _____ 0.00 kW
Fixed Electric Spacer Heater(s) _____ kW
Geothermal Motor(s) _____ kW
Air Conditioning (1 Ton = ~3.5 kW) _____ kW
EV Charger _____ 0.00 kW
Other Load (i.e. Hot Tub/Spa, Well Pump, Sump Pump, Motors, Tank Heaters): _____ 0.00 kW

Time- of- Use (TOU) Program: _____ kW

Electric Thermal Storage (ETS) Heater(s) kW + Total Water Heater kW

Total Connected Load 0.00 kW

Print Name _____

Signature _____ Date _____

All fields of this form must be completed. If areas are left blank the form will be returned for the additional information. If you need assistance filling out this form, consult with your electrician.

STATEMENT OF AUTHORITY

1. This Statement of Authority relates to an entity named _____, and is executed on behalf of the entity pursuant to the provisions of Section 38-30-172, C.R.S.

2. The entity is a:

- Corporation
- Non-Profit Corporation
- Trust
- Business Trust
- Governmental Subdivision or Agency
- Unincorporated Non-Profit Association
- Other: _____
- Limited Liability Company
- General Partnership
- Limited Partnership
- Registered Limited Liability Partnership
- Registered Limited Liability Limited Partnership
- Limited Partnership Association

3. The entity was formed under the laws of the State of: _____.

4. The mailing address for the entity is: _____.

5. The **name** and **position** of each person authorized to execute instruments conveying, encumbering, or otherwise affecting title to real property on behalf of the entity is:

- Name: _____,
- Position: _____

6. (Optional)³ The authority of the foregoing person(s) to bind the entity is limited is not limited as follows:

Define limit or no-limit of signature authority. i.e. LPEA easement documents.

7. (Optional) Other matters concerning the manner in which the entity deals with its interest(s) in real property: Delete if not necessary.

Owner of Record: _____

Signature: _____

Printed Name: _____

Position: _____

The foregoing instrument was acknowledged before me on this _____ day of _____, 20____.

STATE OF: _____)
 COUNTY _____) ss
 OF: _____)

Witness my hand and official seal.

Notary Public

My Commission Expires

¹ This form should not be used unless the entity is capable of holding title to real property.
² This Statement of Authority must be recorded to obtain the benefits of the statute.
³ The absence of any stated limitation shall be prima facie evidence that no limitation exists.

AFTER RECORDING RETURN TO:
 La Plata Electric Association, Inc.
 Attn. Right of Way
 PO Box 2750
 Durango, CO 81302-2750

CLEAN SOIL

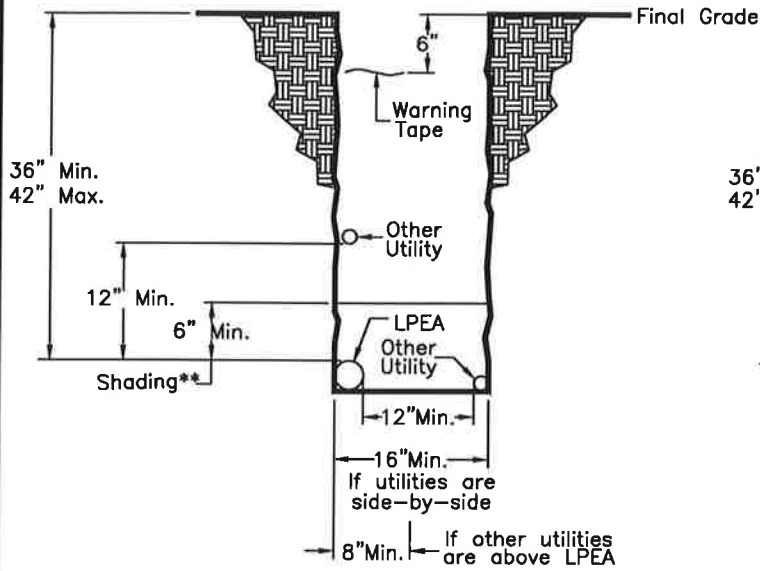

ROCKY SOIL

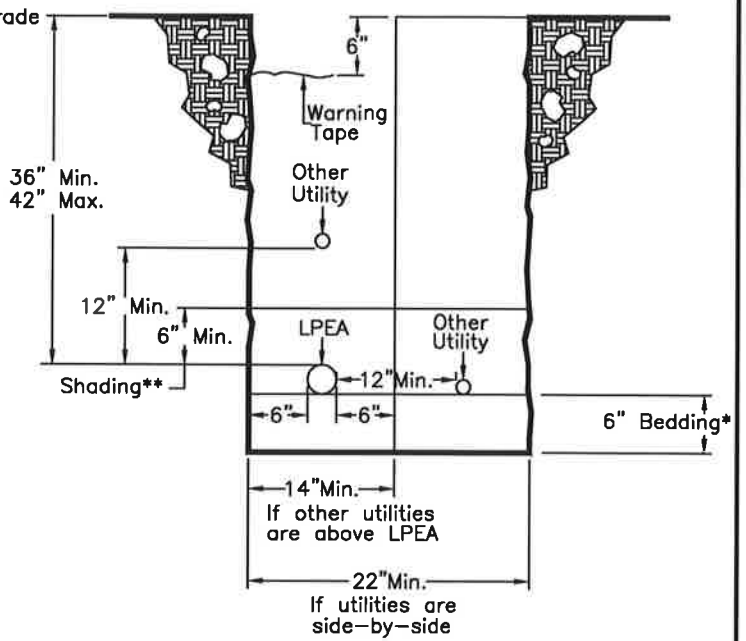

SOLID ROCK

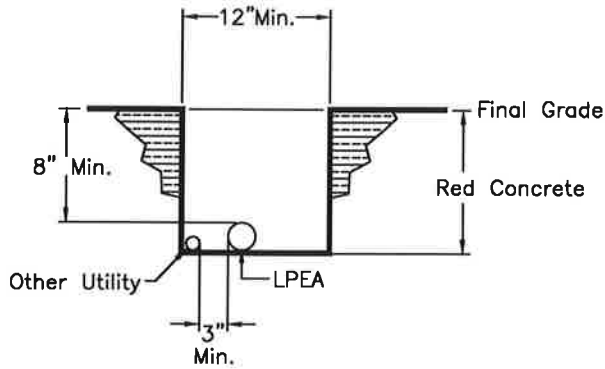

IRRIGATION DITCH

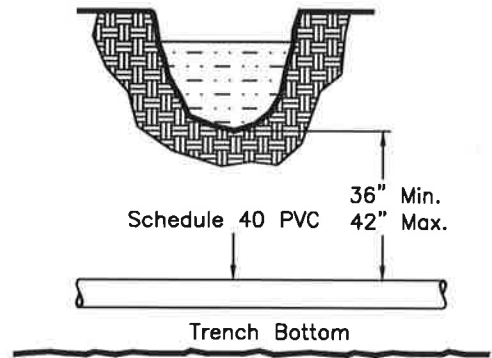

NOTES:

- 3" GREY SCHEDULE 40 PVC SLEEVE REQUIRED ON ALL SINGLE PHASE ROAD CUTS.
- 6" GREY SCHEDULE 40 PVC SLEEVE REQUIRED ON ALL THREE PHASE ROAD CUTS.
- 6" HDPE PIPE WILL BE UTILIZED FOR ALL BORES

WARNING TAPE SUPPLIED BY LPEA; INSTALLED BY CUSTOMER.

* BEDDING (ROCK FREE DIRT OR SAND) TO BE SUPPLIED AND INSTALLED BY CUSTOMER.

** SHADING (ROCK FREE DIRT OR SAND) TO BE SUPPLIED BY CUSTOMER; INSTALLED BY LPEA CREW. SHADING MUST BE SUPPLIED IN 20' INCREMENTS ALONG THE DITCH.

NO.	DATE	REVISIONS	APP'D
1	2/27/24		RMW

LPEA

La Plata Electric Association, Inc.
A Touchstone Energy Cooperative

PO Box 2750
Durango CO 81302-2750
COLORADO 32 LaPLATA

DRAWN JDD
CHECKED
APPROVED
DATE 06/26/08
FILE NAME SPEC1.dwg

UG TRENCH AND BEDDING SPECIFICATIONS	
PRIMARY	
SCALE NONE	DRAWING NUMBER SPEC 1

CLEAN SOIL

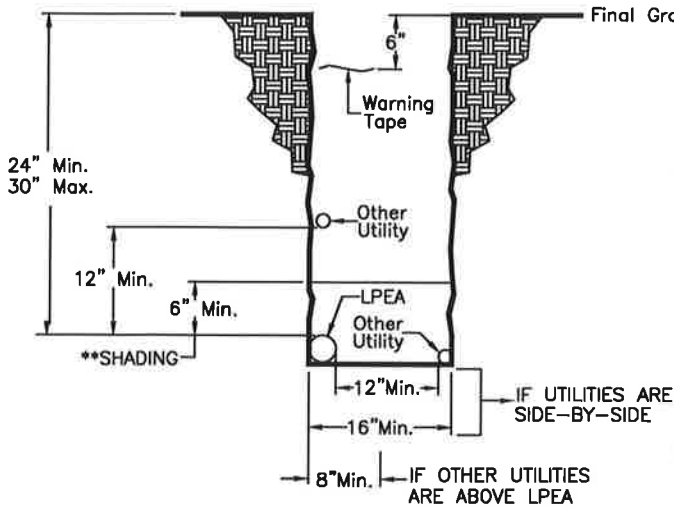

ROCKY SOIL

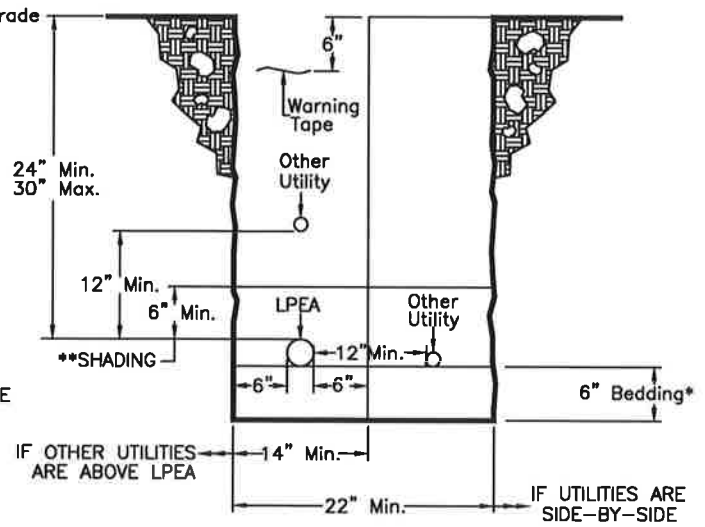

SOLID ROCK

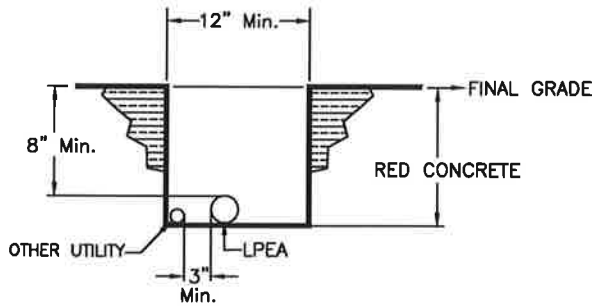

IRRIGATION DITCH

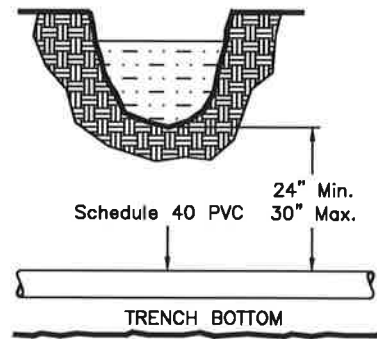

NOTES:

- 3" GREY SCHEDULE 40 PVC SLEEVE REQUIRED ON ALL SINGLE PHASE ROAD CUTS.
- 3" HDPE PIPE WILL BE UTILIZED FOR ALL SINGLE PHASE BORES
- 6" GREY SCHEDULE 40 PVC SLEEVE REQUIRED ON ALL THREE PHASE ROAD CUTS.
- 6" HDPE PIPE WILL BE UTILIZED FOR ALL THREE PHASE BORES

FLOW FILL NOT ACCEPTED.

WARNING TAPE SUPPLIED BY LPEA; INSTALLED BY CUSTOMER.

SERVICES 400 AMP OR GREATER REQUIRE CONSULTATION WITH A STAKING ENGINEER REGARDING SECONDARY REQUIREMENTS.

SERVICES GREATER THAN 800 AMP WILL REQUIRE PARALLEL RUNS OF CONDUIT OF ADEQUATE SIZE FOR THE REQUIRED CONDUCTOR. CUSTOMER MUST CONSULT WITH STAKING ENGINEER.

- * BEDDING (ROCK FREE DIRT OR SAND) TO BE SUPPLIED AND INSTALLED BY CUSTOMER.
- ** SHADING (ROCK FREE DIRT OR SAND) TO BE SUPPLIED BY CUSTOMER; INSTALLED BY LPEA CREW.
- ** SHADING MUST BE SUPPLIED IN 20' INCREMENTS ALONG THE DITCH.

NO.	DATE	REVISIONS	APP'D
1	4/24/21	Removed suggested secondary wire type table	MAF
2	4/24/21	Corrected HDPE sizes on bores	MAF
3	4/24/21	Added required engineer consultation for services of 400 amps or greater	MAF
4	2/27/24		RMW

LPEA
 La Plata Electric Association, Inc.
 A Touchstone Energy Cooperative
 PO Box 2750
 Durango CO 81302-2750
 COLORADO 32 LaPLATA

DRAWN JDD
CHECKED
APPROVED
DATE 06/26/08
FILE NAME SPEC2.dwg

UG TRENCH AND BEDDING SPECIFICATIONS	
SECONDARY	
SCALE NONE	DRAWING NUMBER SPEC 2

8" - 17" TRENCH DEPTH

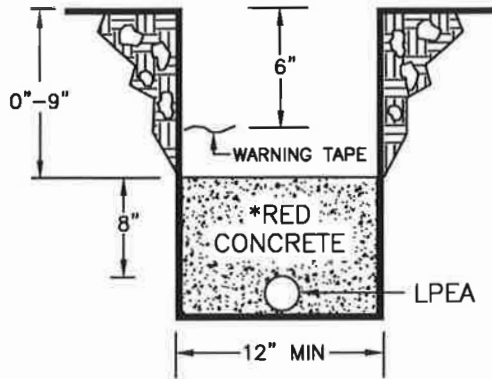

18" - 23" TRENCH DEPTH

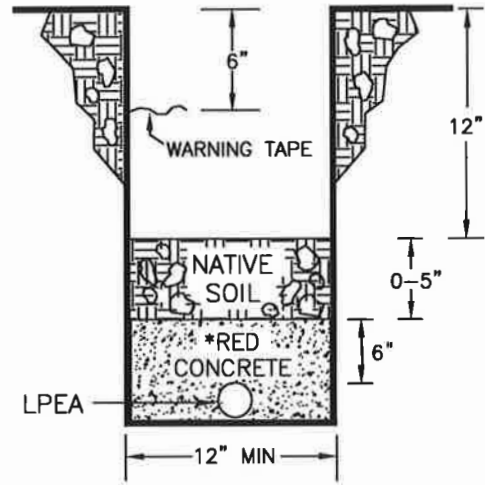

30"-35" TRENCH DEPTH

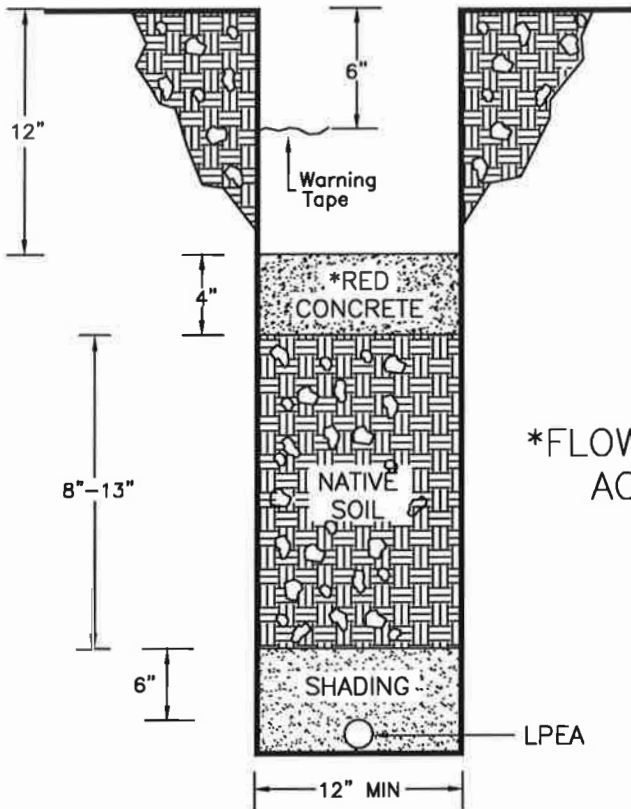

24"-29" TRENCH DEPTH

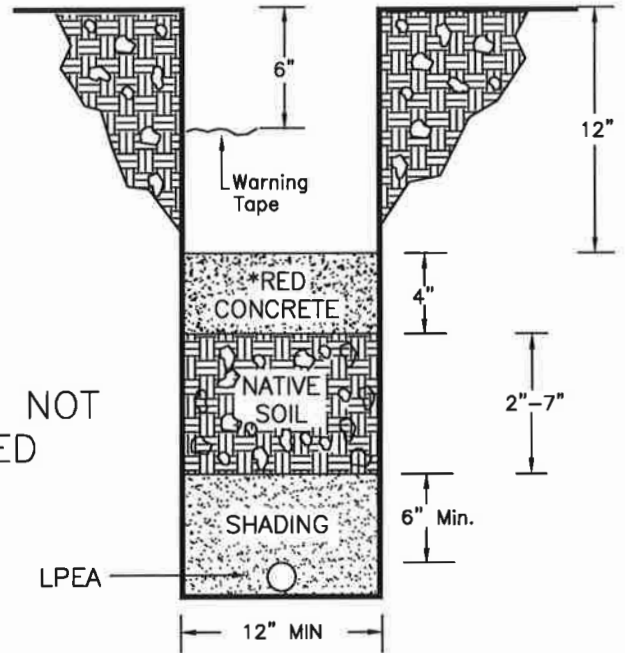

*FLOW FILL NOT ACCEPTED

NO.	DATE	REVISIONS	APP'D
1	2/27/24		RMW

LPEA
 La Plata Electric Association, Inc.
 A Touchstone Energy Cooperative 
 PO Box 2750
 Durango CO 81302-2750
 COLORADO 32 LaPLATA

DRAWN	MF
CHECKED	
APPROVED	
DATE	06/30/08
FILE NAME	SPEC3.dwg

UG TRENCH
 SHALLOW DEPTH
 PRIMARY / SECONDARY

SCALE	NONE	DRAWING NUMBER	SPEC 3
-------	------	----------------	--------

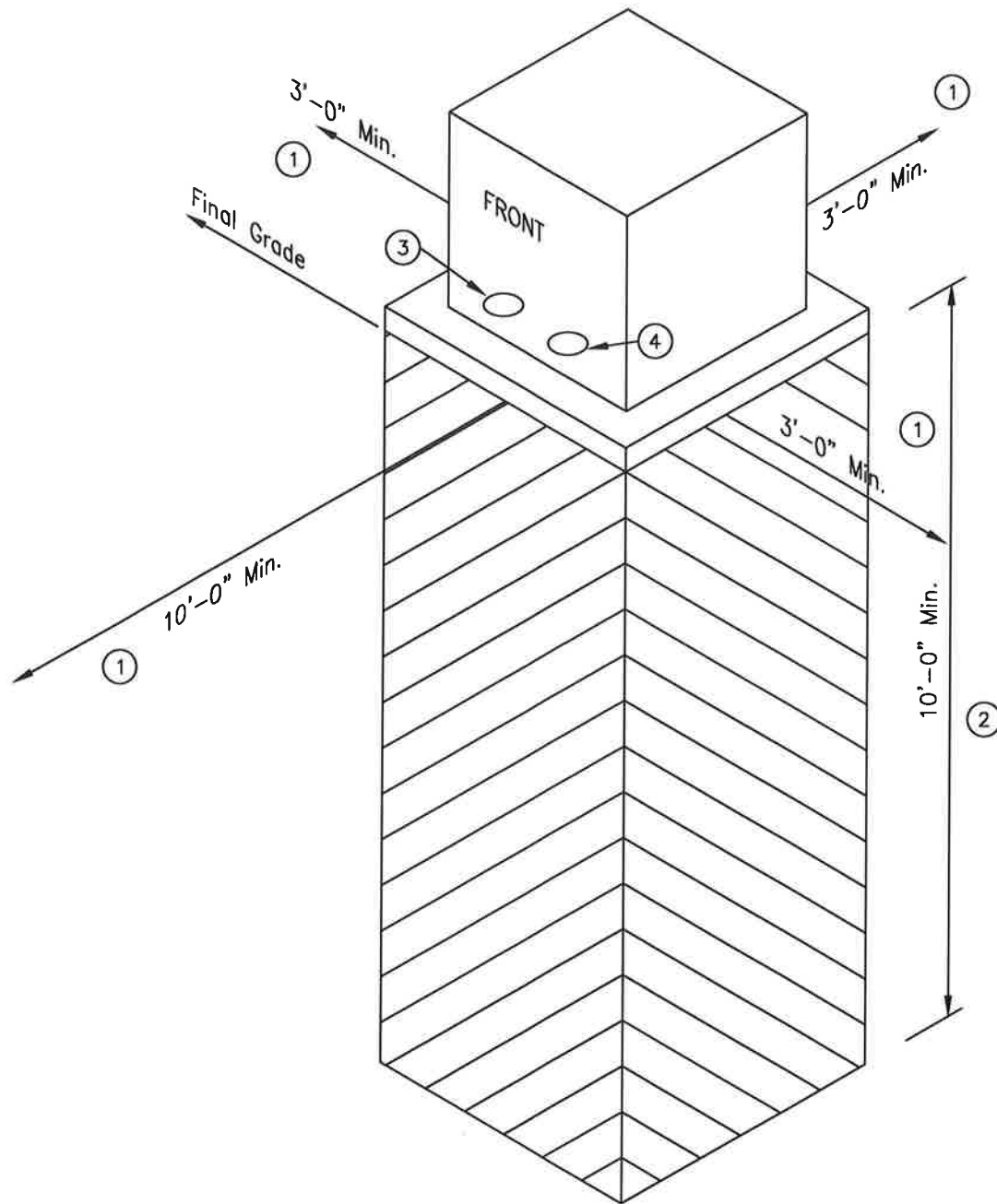

Notes:

- ① Distance required for access. No permanent structures or fences allowed in this area and 4ft from fire hydrants
- ② No other utilities allowed in the defined area under the equipment
- ③ Approximate location of primary conduit
- ④ Approximate location of secondary conduit

NO.	DATE	REVISIONS	APP'D
1	2/27/24	Removed suggested secondary wire type table	RMW

LPEA
 La Plata Electric Association, Inc.
 A Touchstone Energy Cooperative

PO Box 2750
 Durango CO 81302-2750
 COLORADO 32 LaPLATA

DRAWN	RPC
CHECKED	
APPROVED	
DATE	02/27/24
FILE NAME	SPEC4.dwg

**PAD MOUNT
 UG EQUIPMENT
 SPECIFICATION**

SCALE	DRAWING NUMBER
NONE	SPEC 4

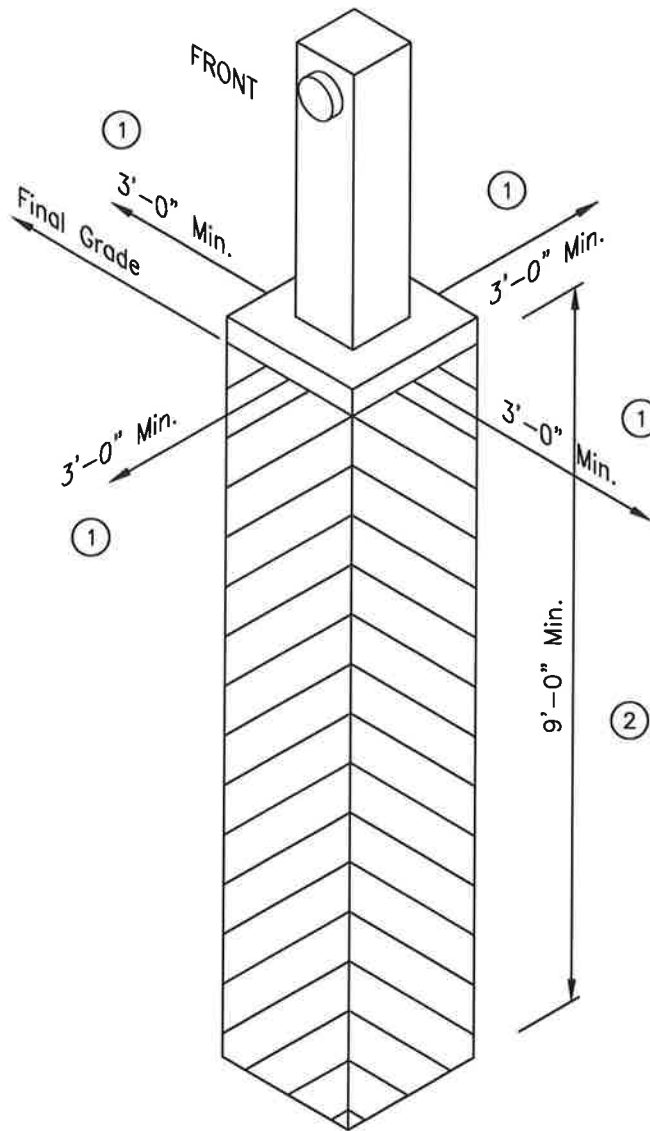

Notes:

- ① Distance required for access. No permanent structures or fences allowed in this area and 4ft from fire hydrants
- ② No other utilities allowed in the defined area under the equipment

NO.	DATE	REVISIONS	APP'D	DRAWN	PEDESTAL SPECIFICATION	
1	2/27/24		RMW	RPC	SCALE	DRAWING NUMBER
				CHECKED	NONE	SPEC 5
				APPROVED		
				DATE		
				02/27/24		
				FILE NAME		
				SPEC5.dwg		

LPEA
 La Plata Electric Association, Inc.
 A Touchstone Energy Cooperative 
 PO Box 2750
 Durango CO 81302-2750
 COLORADO 32 LaPLATA



CT Metering Requirements

Single phase services 400 – 800 Amps
Three phase services 400 - 3500 Amps*

All services require a Current Transformer (CT) meter if service is greater than 320 Amps, this is dictated from the Load Data Sheet submitted. It is the member's responsibility to provide equipment and conductor from the point of service to the meter. The point of service is based on transformer location.

Use the following chart to determine where the point of service is for your project:

<u>If the transformer is:</u>	<u>The point of service is:</u>
Pad-mounted	The secondary connector blocks
Overhead with overhead secondary conductor to a building	The secondary bushings on the side of the transformer
Overhead with underground secondary conductor to a meter rack or a meter on a building	The secondary connector points in a new or existing secondary junction box at the base of the pole

Required Equipment

It is the member's responsibility to provide the following:

1. Secondary service conductor in conduit with 20 ft of tails from the point of service to the CTs.
2. A hinged CT cabinet:
 - Single Run Minimum Size: 24"x24"x12" for single run
 - Parallel Runs Minimum Size: 24"x30"x12" for parallel runs

****Please** upsize the cabinet if you are using larger conductors and if using multiple runs of conductor. Make sure it can all be accommodated without too tight of a fit. If in doubt 'bigger might be better'.
3. A CT cabinet with metering equipment mounted on the building or on a meter rack, no more than 15 ft from the meter socket.

LPEA will provide the CTs, CT meter socket, CT meter and make all connections from CTs to meter. Note for a single-phase installation, there will be 2 CT and a 3WCL20 4S meter. For a three-phase installation, there will be 3 CTs and a 4WCL20 9S meter set.

CT Meter Installation Check List

1. Once the work order has moved into Construction, please contact the LPEA Meter Shop to schedule to pick up the CTs and meter socket.

Send an email to metershop@lpea.coop with the following information:
Work order number, service address, amperage size of service, electrician's name/phone number.

*If greater than 3500A please contact metershop@lpea.coop

Please allow 1 week – 2 weeks to pick up CTs and meter socket.

2. Contact the appropriate LPEA Line Superintendent to get on the schedule.

Durango: Toby Allred (970) 382-3583

Pagosa Springs: Garrett Hammer (970) 946-9434

3. Build the metering location. Please see **Drawing TR-40, page 3**. Install the CT can, CT's and socket in a rack or on the building utilizing the following criteria:

- The hinged CT cabinet shall meet a minimum of NEMA 3R standards, will be NRTL listed and labeled as a CT enclosure (UL and/or third party certification). In addition, it shall:
 - Be furnished with factory installed landing pads and lugs for phase and neutral conductors.
 - Have a neutral lug for the neutral bus which will accommodate one #12 AWG solid through two #10 AWG stranded wire(s) for the metering neutral conductors.
 - Have barriers between adjacent compartment areas.
 - Be equipped with a hasp for a Company padlock with a 5/16" diameter shackle.
- Approved and recommended CT cabinets may be viewed at:
<https://ampmfg.com/products/current-transformer-cabinets/xcel-energy-except-xcel-energy-wi-mi>
- The CTs shall be installed in such a manner that:
 - The secondary metering terminals are readily accessible from the door of the CT compartment.
 - The installation height of the CTs shall be between two (2) feet minimum and six (6) feet maximum measured from the center of the CTs to final grade.
 - The minimum clearance from the bottom of a wall-mounted CT cabinet to final grade shall be one (1) foot.
- The CTs shall be mounted such that the H1 "white dot" marking for polarity is on the line side. As the saying goes "Dot to the pot".
- 400A – 800A services will have bar-type CTs provided by LPEA. If the CT cabinet includes bars, these shall not be greater width than 3".
- 801A – 3500A CT cabinets shall have a removable bus section with a twelve (12) inch minimum length, four (4) inch maximum width, and an insulated CT support which will accommodate window-type CTs. The removable bus section shall have an enclosed screw type compression terminal to accommodate a minimum #12 AWG metering potential conductor on the line-side section of the bus.
- The line-side and load-side conductors shall be terminated in the CT cabinet.
- Additional customer-owned equipment is **not** permitted inside the CT cabinet.

4. Contact LPEA Engineering at (970) 382-3555 to schedule a meterman to wire the service.

5. Following approval by the State Electrical Inspector, contact LPEA Engineering at (970) 382-3555 with the permit release number to request a CT meter set. The meter will only be set and the service energized after the electrical inspection is passed. This process can take up to 3 business days.



P.O. Box 2750 Durango, CO 81302-2750
 Phone: (970) 247-5786 • Fax (970) 247-2674
www.lpea.coop

DRAWING TR-40

CURRENT TRANSFORMER MOUNTING REQUIREMENTS FOR CABINETS AND SWITCHGEAR

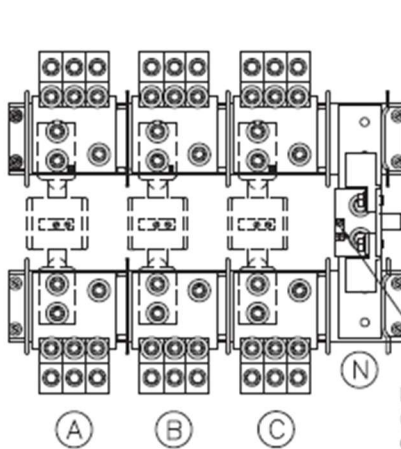
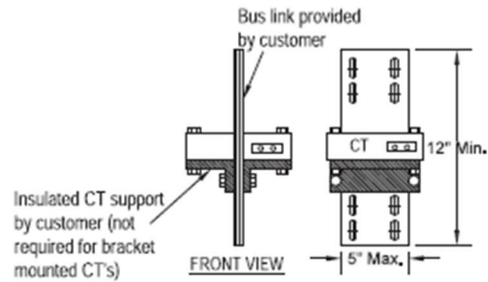
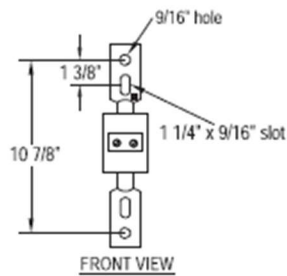

Lug suitable for #12 copper wire.
 Lugs suitable for (1)-#12 or (2)-#10 copper wires.

For services 400-800 Amps

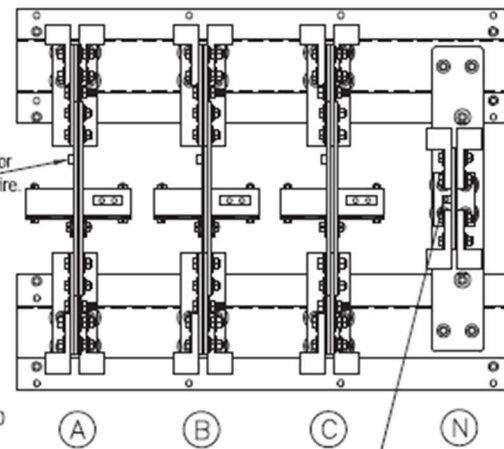

Lugs suitable for (1)-#12 or (2)-#10 copper wires.

For services 801 - 4000 amps

NOTES:

1. White dot on CT is polarity mark and faces line-side.
2. See Section 4.12 for current transformer cabinet requirements.
3. Line side bus bar hole pattern shall have NEMA 2-hole spacing and be centered on bar in WI and MI only.

Highlights

from the “Line Extension Policy” and Other New Service Info

All electric line extensions must be installed according to LPEA’s current “Line Extension Policy” and “Electric Service Regulations”. These documents are available online at <https://lpea.coop/policies> or copies will be provided upon request.

DEVELOPER RESPONSIBILITIES

Prior to LPEA personnel staking the development, the developer shall:

- Provide an accurate plat of the development, including dedicated easements, to be used in design and cost estimating.
 - Preliminary plats may be used for early design and cost estimating; however, a hard copy of the final, recorded plat must be provided prior to preparation of contracts or the collection of contract money.
- Prior to staking of equipment locations, all lot corners and property lines must be identified, clearly marked and final grade must be established.

DEVELOPMENT DESIGN

LPEA staking personnel use the following guidelines in development design:

- Provision for electric service to all lots of the development will be made.
- Whenever practicable, LPEA equipment will be located at front lot corners and common to roadways, streets and alleys in order to provide access for installation, maintenance, replacement and/or removal of the equipment. The design shall, also, incorporate an equipment set-back of not less than ten (10) feet from the edge of the roadway or five (5) feet from the edge of the sidewalk to allow for snow removal and roadway maintenance.
- Forty-two (42) inches of clearance (a minimum of thirty-six (36) inches) must be maintained between sides and backs of LPEA primary equipment (i.e. pad mount transformers, junction boxes, switchgear) and all communication equipment. A minimum of ten (10) feet of clear space containing no obstructions is required in front of LPEA primary equipment.
- Whenever practicable, the design shall incorporate an alternate source of power to the development to allow for load switching, load balancing and a back-up source of power in case of equipment failure or failure caused by dig-in.

Highlights

from the "Line Extension Policy" and Other New Service Info

LPEA/CUSTOMER INSTALLED EQUIPMENT

LPEA shall install all equipment necessary to complete your service requirements. This may include:

- Primary cable
- Transformers
- Secondary/service wire to point of metering
- Meter pedestal adjacent to the transformer
- Meter

Electric service will be provided to an Association-owned meter. Installation, ownership, and maintenance of the service wire from the meter to the load location are the responsibility of the Applicant. Law prohibits LPEA from performing work on the customer's side of the disconnect switch, as well as the tampering of LPEA-owned facilities by others.

The customer's installation must be approved and tagged by the Colorado State Electrical Inspector in a manner visible to the LPEA representative before a meter will be installed.

TRENCHING AND BEDDING

All boring, trenching, bedding, and backfilling are to be provided by the customer without cost to LPEA and with provisions made for other utilities in accordance with their requirements. Please see the "Underground Trench and Bedding Specifications" included in this packet for more detail.

- In trenches of normal depth, electrical conduit will be placed at a minimum depth of thirty-six (36) inches and a maximum depth of forty-two (42) inches.
- In trenches of shallow depth, electrical conduit must be covered with red-dyed concrete (Flow-fill is not acceptable). Installation must be inspected by an LPEA representative.
- Warning tape is required at six (6) inches below final grade in all trenches.

Highlights

from the "Line Extension Policy" and Other New Service Info

- Conduits installed in roadways are to be backfilled and compacted in a manner consistent with road compaction requirements of the local governing body (state, county, city, town, etc.).
- No LPEA lines will be energized until warning tape is installed and the trench has been completely backfilled.

LOCATION OF EXISTING UNDERGROUND FACILITIES

State law requires location of all underground utilities present on your property prior to any digging. Locates are arranged by calling the Utility Notification Center of Colorado (UNCC) at (800) 922-1987 or 811.

RIGHTS-OF-WAY/EASEMENTS

LPEA requires easement for all new electric lines. Typical easement width is 20 feet. If it is necessary to cross another's property to serve the customer, an LPEA easement is required from the other property owner.

Any special considerations of easements and/or permits must have LPEA approval.

Easements must be written, approved, signed and notarized before the job is released to construction. Any costs associated with the acquisition of right-of-way are the responsibility of the customer.

TREE TRIMMING

To increase safety, reduce outages, and prevent expensive damage, LPEA will periodically trim or remove vegetation from the electric line right-of-way.