

Residential Work Order

Below is a checklist to assist you with your new construction project:

In order to expedite the assignment of your job to a staking engineer, complete the following:

- Property owner to complete and sign the "Application for Work Order" with accurate Service Address (assigned by the county)
 - Complete the "Load Data Sheet", which contains crucial information to ensure an appropriately designed electric service
(if you need assistance filling out this form, consult with your electrician)
 - Pay the required Design Fee (Credit card payments are not accepted for New Construction) \$300 non-refundable
 - Provide the most current and recorded copy of Warranty Deed. Name on Warranty Deed must match name on application for work order.
 - Letter of credit for new members who do not have established credit listing with LPEA
- Submit the above by mail or at the office in Durango or Pagosa Springs.*

- Upon receipt of the above, the first available staking engineer will contact you to arrange an appointment to meet at the site to discuss your job. Please make sure property pins are in place or property boundaries are marked prior to this meeting.
- After the on-site meeting, the staking engineer will draw your job, compute the construction cost, and contact you.
(NOTE: The cost you receive is good for 30 days.)

Job will be released to construction for scheduling after you complete the following.

- Sign and notarize necessary easements and contracts
- Pay construction costs (credit card payments are not accepted)
- Contact LPEA at (970) 247-5786 and ask to speak with the Line Superintendent, in Durango (La Plata County) or Pagosa Springs (Archuleta County), to coordinate scheduling for construction before you start trenching or clearing right-of-way. Be sure to reference your LPEA Work Order Number when you call.
- Clear right-of-way as required.

For Underground Line Extensions

Prior to digging trench, obtain:

- Existing underground utility locations with the Utility Notification Center of Colorado at (800) 922-1987 or 811
- Any required excavation permits
- Verify that trench location will be within dedicated right-of-way
- Dig your trench. All trenching must be per LPEA specifications. **(A \$600 fee will be charged to the customer if LPEA construction crews show up at the job site and the trench is not ready or if trench does not meet NESC depth specifications.)**

- Notify the LPEA Line Superintendent that you are ready for construction to proceed.
- LPEA extends line and installs electrical facilities to metering point. ***You are responsible for everything past the metering point.***
- Contact Colorado State Electrical Inspector to inspect your service; www.dora.state.co.us/electric

Contact LPEA to have your meter installed after:

- Trench has been backfilled (if underground electrical facilities are installed)**
- Your service has been inspected and green-tagged by the Colorado State Electrical Inspector
- Call La Plata Electric at 970-247-5786 with permit # from Colorado Electrical Inspector.
- LPEA energizes line and meter

LA PLATA ELECTRIC ASSOCIATION, INC.

Application for Work Order

Residential

Revised 08/03/2021

Property Owner: _____ Spouse: _____
SSN: _____ Spouse SSN: _____
Service Address: _____ City: _____ Zip: _____
Subdivision: _____ Block: _____ Lot #: _____
Billing Address: _____ City/State: _____ Zip: _____
Home Phone: _____ Cell Phone: _____
Work Phone: _____ Email Address: _____
Service is: [] New [] Upgrade Relocation Project Contact: _____

The undersigned (hereinafter called the "Applicant") hereby applies for and agrees to purchase electric energy from the La Plata Electric Association, Inc. (hereinafter called the "Association") upon the following terms and condition:

- 1. The Applicant will comply with and be bound by the provisions of the Articles of Incorporation and Bylaws of the Association, and such rules, regulations, and policies as may periodically be adopted by the Board of Directors of the Association.
2. The Applicant agrees, when electric service is available to these premises, to pay the monthly charge in accordance with the applicable rate schedule. Applicant understands and agrees that the Association's responsibility does not extend beyond the point of the Applicant's ownership of the Applicant's service wires with the exception of the electric meter or pre-pay metering and associated equipment.
3. The Applicant hereby agrees to support and assist the Association in obtaining the right, privilege and easement to construct, operate and maintain the necessary electric facilities together with full right of ingress and egress, as may be necessary to extend and maintain this service. If the Association must purchase or condemn right-of-way, it will do so at the sole expense of the Applicant. The Applicant agrees it shall be solely responsible for the Association's actual expenses for: the acquisition, purchase or condemnation of right-of-way; surveying; special archaeological or environmental studies and permitting; the expenses associated with the construction of roads and reclamation of land damage. The Applicant shall pay to the Association such estimate of costs prior to the Association's commencement of construction. No portion of such payment of expenses is refundable to the Applicant. Any necessary subsequent costs related to permitting and/or renewals or extensions of rights-of-way shall be borne solely by the Applicant, his/her/its heirs, successors or assigns.
4. The Applicant hereby also grants the Association the right to cut and trim trees and shrubbery to the extent necessary to keep them clear of the electric facilities. All boring and trenching provided by the Applicant for the installation of the underground system must be located within the dedicated easements and the Applicant hereby warrants that the location of all required boring and trenching provided by the Applicant so conforms. Any boring and trenching found now, or in the future, outside of the dedicated easement will be relocated within the dedicated easements, and all costs for the relocation will be the responsibility of the Applicant.
5. Upon mutual acceptance, this application for electric service shall constitute a valid binding agreement between Applicant and the Association and shall continue in force until canceled by the Applicant with at least a twenty-four hour prior written notice, which must be received by the Association during regular office hours. This agreement may be terminated by the Association for any reason authorized by the Association's Bylaws or for a material breach of this agreement, including failure of the Applicant to comply with the rules, regulations and bylaws of the Association. The Applicant will remain liable for all charges incurred for electric service herein until the Association is advised of a change in the service.
6. The Applicant agrees to pay a deposit with the Association, such service security deposit as is required by the rules and regulations of the Association. The Applicant hereby grants and Association takes a security interest in said deposit as collateral for service to be applied by the Association, upon any non-payment, termination of service, insolvency, or petition for bankruptcy by undersigned Applicant. The Association shall apply said deposit to bills due the Association and refund any unused portion of deposit upon termination of electric service to the Applicant.
7. If this agreement is for the installation of new service it should be noted that, if this agreement is cancelled subsequent to design and engineering, but prior to construction and connection of new electric service, the Applicant shall be held liable for all costs incurred by the Association in the performance of such activities. It should be further noted that, new electric service and temporary construction service under this agreement are available without actual connection for only one (1) year, thus Applicant should plan to have permanent wiring completed and must request actual connection within that year, or this agreement will terminate and Applicant shall pay the Association for any outstanding service charges arising from this agreement.
8. The Association will schedule construction projects with the Applicant for a specific date upon request by the Applicant or their representative. Any cost overrun attributable to delays or changes caused by the Applicant or their representative will be the responsibility of the Applicant. If your trench will not be ready on the agreed date, you must notify the Association's construction supervisory personnel on or before 7a.m. of the agreed date. If the Association's construction crews show up and, for reasons attributable to a failure of the Applicant or their representative, cannot perform required construction, a \$600 fee will be charged to the Applicant.
9. Unless Applicant also signs the Disclaimer of Membership below, this Application shall constitute an application for membership in the Association. As a member of the Association, Applicant assumes no personal liability or responsibility for any debts or liabilities of the Association, and it is expressly understood that Applicant's private property cannot be attached for any such debts or liabilities of the Association. As a member of the Association, the Applicant agrees to comply with and be bound by the provisions of the Articles of Incorporation and Bylaws of the Association, as the same may periodically be lawfully amended. Each member of the Association, or in the case of a joint membership, the holders thereof jointly, or any one of them, but not all, shall be entitled to one (1) vote and no more upon each matter submitted to a vote of the Association's members.

Property Owner

Date: _____

ROUND UP AUTHORIZATION (OPTIONAL)

Yes, I wish to help our communities by rounding up my electric bill.

DISCLAIMER OF MEMBERSHIP (OPTIONAL)

The undersigned hereby chooses not to become a member of La Plata Electric Association, Inc.

As a customer of the Association, the Applicant agrees to comply with and be bound by the provisions of the Articles of Incorporation and Bylaws, as the same may periodically be lawfully amended.

Primary Applicant

Applicant

Date: _____

Applicant



Durango Office:
P.O. Box 2750, Durango, CO 81302
45 Stewart St, Durango, CO 81303
Phone: (970) 247-5786
Pagosa Springs Office:
P.O. Box 305, Pagosa Springs, CO 81147
603 S 8th St, Pagosa Springs, CO 81147
Phone: (970) 247-5786

Single Family Residential Load Data Sheet

Service Location: _____ City: _____
 Property Owner: _____ Phone: _____
 Electrician/Contractor: _____ Phone: _____
 Project Contact: _____ Phone: _____

1. Processing of this form will not be possible if information is incomplete.
2. Significant revision to information on this form may necessitate rescheduling of job.
3. Any costs incurred by changes to design caused by a change in service requirements after construction is started may be charged to the member.

DISTRIBUTIVE GENERATION

Renewables such as PV, Micro-Hydro, Wind _____ **Total Proposed Generation** _____ kW

ELECTRIC LOAD INFORMATION *(required fields)*

Main Disconnect Size _____ Amps _____ Volts _____ Phase _____

Residence Square Footage _____

Connected Load

Lighting @ .003 kW/Sq.Ft. _____ kW

Electric Appliances: (Please check all that apply) _____ kW

_____ Range _____ Water Heater
 _____ Oven
 _____ Dryer

Heating and Air Conditioning:

Electric Heat (Non-ETS) _____ kW
 Fixed Electric Spacer Heater(s) _____ kW
 Geothermal Motor(s) _____ kW
 Air Conditioning (1 Ton = ~3.5 kW) _____ kW
 EV Charger _____ kW

Other Load (i.e. Hot Tub/Spa, Well Pump, Sump Pump, Motors, Tank Heaters): _____ kW

Time- of- Use (TOU) Program: _____ kW

Electric Thermal Storage (ETS) Heater(s) kW + Total Water Heater kW

Total Connected Load _____ kW

Print Name _____

Signature _____ Date _____

All fields of this form must be completed. If areas are left blank the form will be returned for the additional information. If you need assistance filling out this form, consult with your electrician.



Durango Office:
P.O. Box 2750, Durango, CO 81302
45 Stewart St, Durango, CO 81303
Phone: (970) 247-5786
Pagosa Springs Office:
P.O. Box 305, Pagosa Springs, CO 81147
603 S 8th St, Pagosa Springs, CO 81147
Phone: (970) 247-5786

*** * DEPOSITS * ***
New Construction
Residential Electric Service

Any new customer of La Plata Electric Association that has not had previous service with us within the past 12 (twelve) months for a term of one year is required to pay a deposit of up to \$250.00. Options to waive this deposit are listed below.

Alternatives to waive the deposit are as follows:

1. You may provide us with a letter of credit from a current or previous utility company showing the past 12 months' payment history.
2. You may request a credit report through our office. A nationwide credit agency provides this service, and only you can authorize the running of a credit report. It can be authorized over the phone or you may come into our office and apply in person. There is no charge for this service.
3. You may provide us with a referral letter from an assistance agency.

Your deposit will be held until 12 consecutive monthly bills have been paid in a timely manner. If acceptable credit has been established after one year from the permanent connect date of your service, the deposit (including interest) is either refunded as a credit on your account or returned as a check. The interest rate is subject to change the first of every year.

If a deposit is required, it will be billed on your first bill after the meter has been set.

If you have any questions, please feel free to call or write and we will be happy to help. We look forward to serving you in the future.

CLEAN SOIL

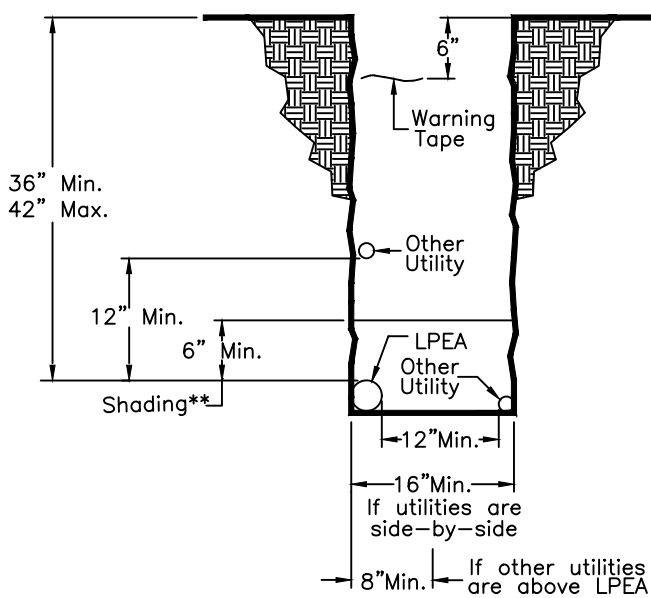

ROCKY SOIL

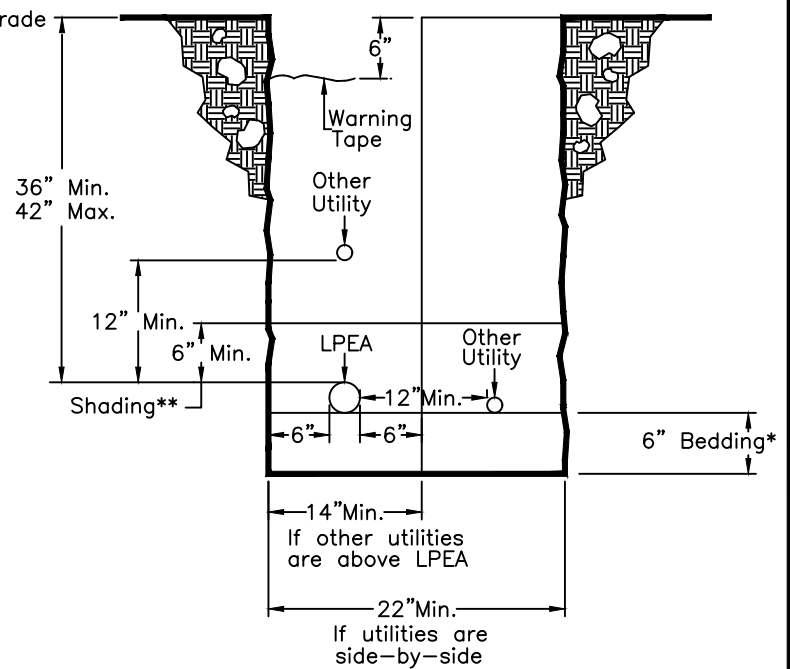

SOLID ROCK

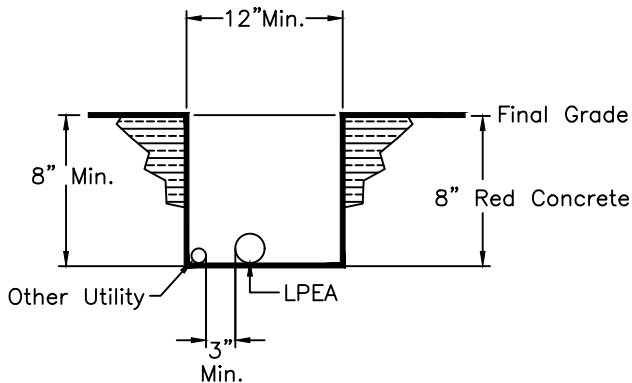

IRRIGATION DITCH

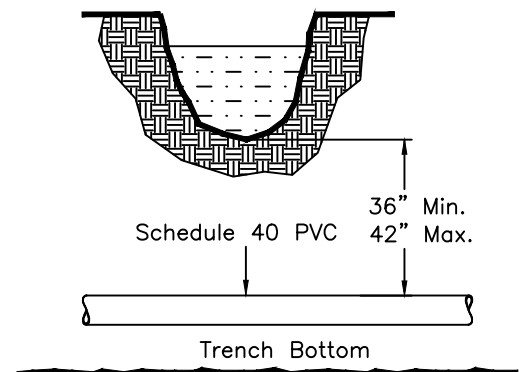

NOTES:

- 3" GREY SCHEDULE 40 PVC SLEEVE REQUIRED ON ALL SINGLE PHASE ROAD CUTS.
- 6" GREY SCHEDULE 40 PVC SLEEVE REQUIRED ON ALL THREE PHASE ROAD CUTS.
- 6" HDPE PIPE WILL BE UTILIZED FOR ALL BORES

WARNING TAPE SUPPLIED BY LPEA; INSTALLED BY CUSTOMER.

- * BEDDING (ROCK FREE DIRT OR SAND) TO BE SUPPLIED AND INSTALLED BY CUSTOMER.
- ** SHADING (ROCK FREE DIRT OR SAND) TO BE SUPPLIED BY CUSTOMER; INSTALLED BY LPEA CREW. SHADING MUST BE SUPPLIED IN 20' INCREMENTS ALONG THE DITCH.

NO.	DATE	REVISIONS	APP'D

LPEA
 La Plata Electric Association, Inc.
 A Touchstone Energy Cooperative
 PO Box 2750
 Durango CO 81302-2750
 COLORADO 32 LaPLATA

DRAWN JDD
CHECKED
APPROVED
DATE 06/26/08
FILE NAME SPEC1.dwg

**UG TRENCH AND
 BEDDING SPECIFICATIONS**
PRIMARY

SCALE NONE	DRAWING NUMBER SPEC 1
----------------------	---------------------------------

CLEAN SOIL

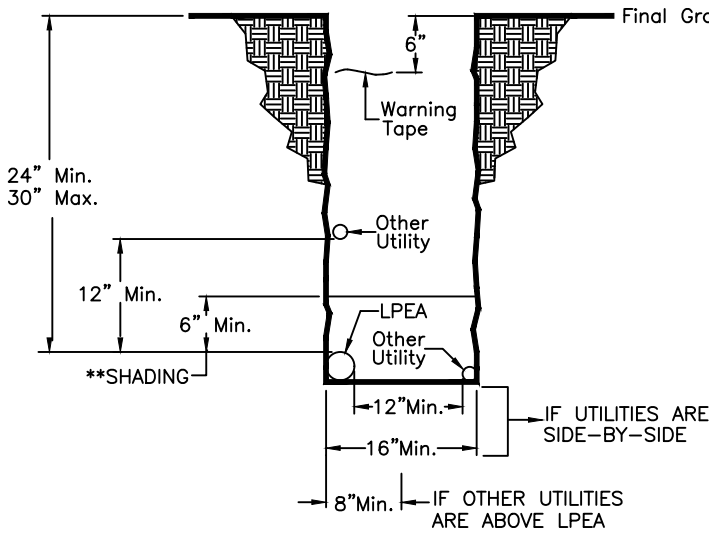

ROCKY SOIL

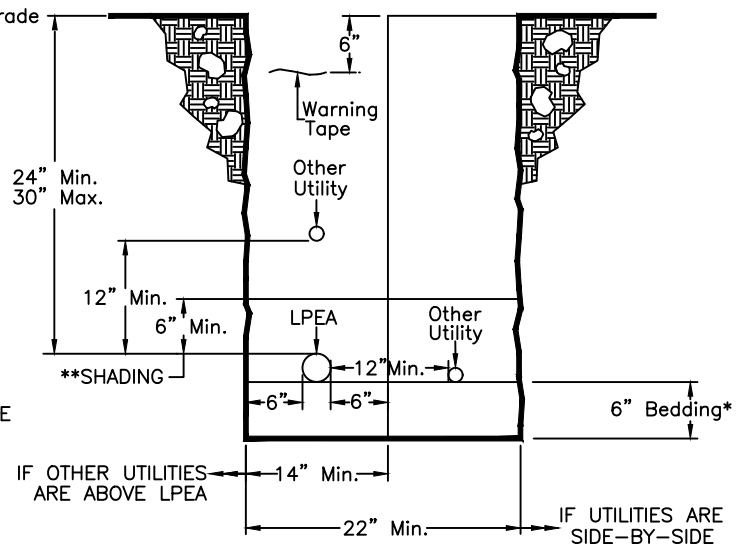

SOLID ROCK

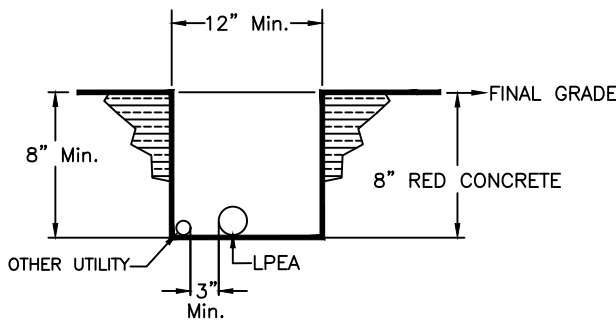

IRRIGATION DITCH

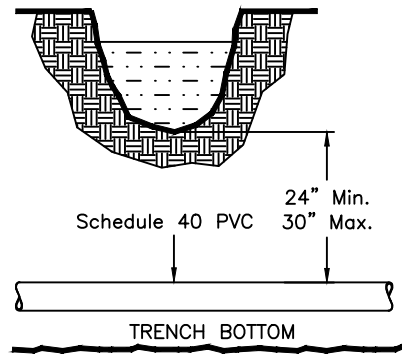

NOTES:

3" GREY SCHEDULE 40 PVC SLEEVE REQUIRED ON ALL SINGLE PHASE ROAD CUTS.

3" HDPE PIPE WILL BE UTILIZED FOR ALL SINGLE PHASE BORES

6" GREY SCHEDULE 40 PVC SLEEVE REQUIRED ON ALL THREE PHASE ROAD CUTS.

6" HDPE PIPE WILL BE UTILIZED FOR ALL THREE PHASE BORES

FLOW FILL NOT ACCEPTED.

WARNING TAPE SUPPLIED BY LPEA; INSTALLED BY CUSTOMER.



SERVICES 400 AMP OR GREATER REQUIRE CONSULTATION WITH A STAKING ENGINEER REGARDING SECONDARY REQUIREMENTS.

SERVICES GREATER THAN 800 AMP WILL REQUIRE PARALLEL RUNS OF CONDUIT OF ADEQUATE SIZE FOR THE REQUIRED CONDUCTOR. CUSTOMER MUST CONSULT WITH STAKING ENGINEER.

* BEDDING (ROCK FREE DIRT OR SAND) TO BE SUPPLIED AND INSTALLED BY CUSTOMER.

** SHADING (ROCK FREE DIRT OR SAND) TO BE SUPPLIED BY CUSTOMER; INSTALLED BY LPEA CREW.

** SHADING MUST BE SUPPLIED IN 20' INCREMENTS ALONG THE DITCH.

NO.	DATE	REVISIONS	APP'D	 La Plata Electric Association, Inc. A Touchstone Energy Cooperative  PO Box 2750 Durango CO 81302-2750 COLORADO 32 LaPLATA	DRAWN JDD	UG TRENCH AND BEDDING SPECIFICATIONS SECONDARY	
1	4/27/21	Removed suggested secondary wire type table	MAF		CHECKED		
2	4/27/21	Corrected HDPE sizes on bores	MAF		APPROVED		
3	4/27/21	Added required engineer consultation for services of 400 amps or greater.	MAF		DATE 06/26/08	SCALE NONE	DRAWING NUMBER SPEC 2
					FILE NAME SPEC2.dwg		

8" - 17" TRENCH DEPTH

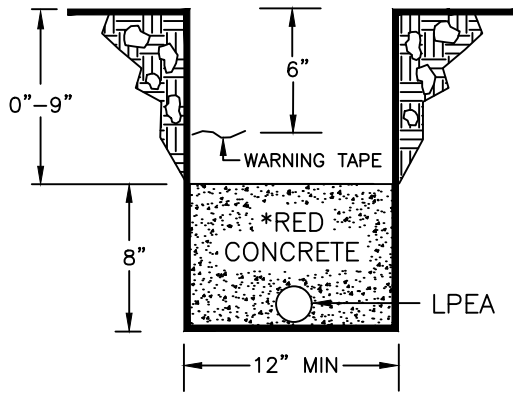

18" - 23" TRENCH DEPTH

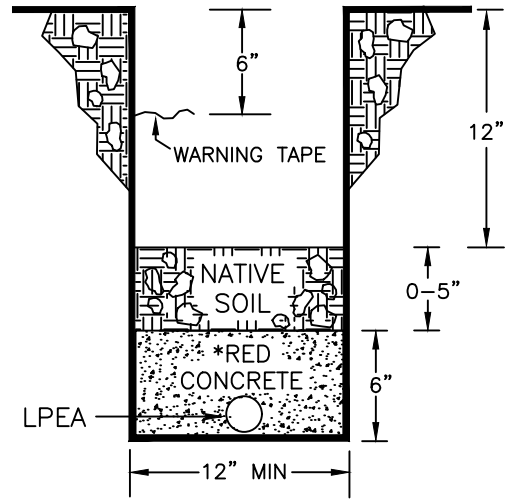

30"-35" TRENCH DEPTH

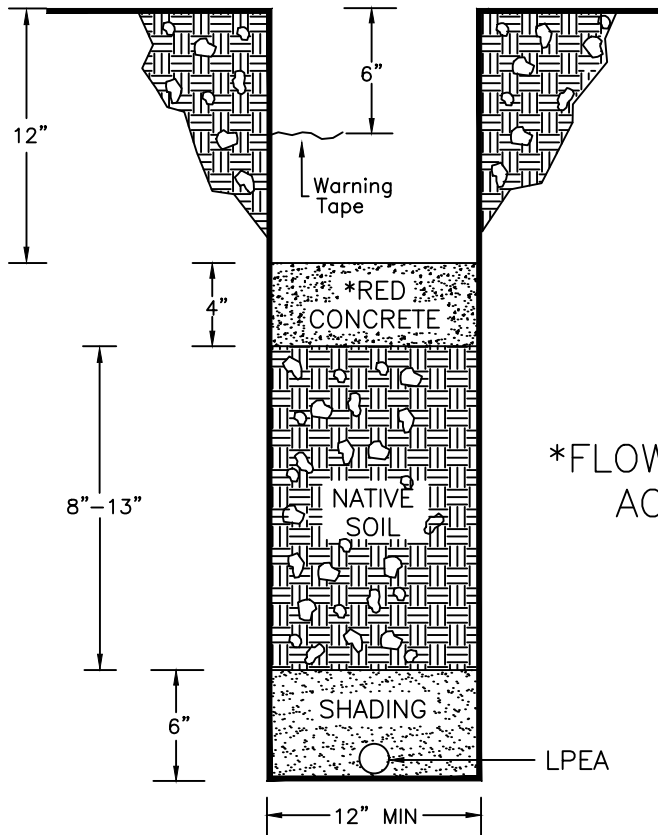

24"-29" TRENCH DEPTH

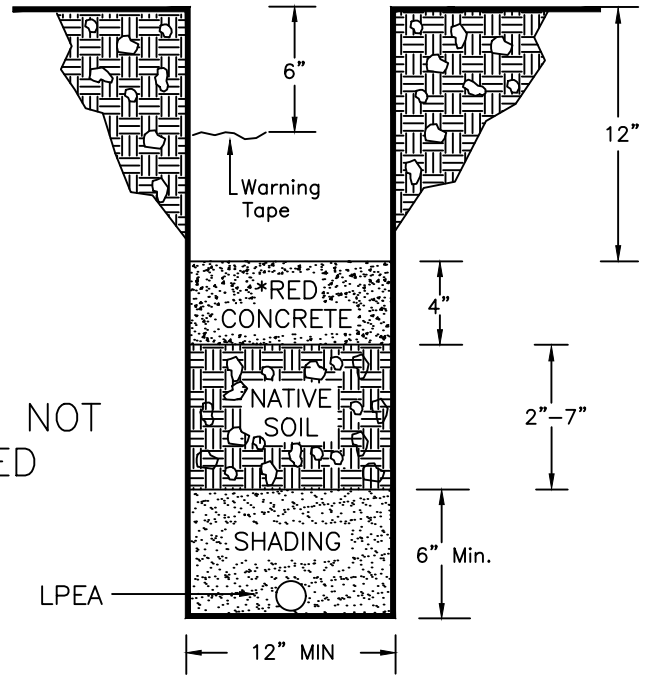

*FLOW FILL NOT ACCEPTED

NO.	DATE	REVISIONS	APP'D

LPEA

La Plata Electric Association, Inc.

A Touchstone Energy Cooperative

PO Box 2750
Durango CO 81302-2750
COLORADO 32 LaPLATA

DRAWN MF

CHECKED

APPROVED

DATE 06/30/08

FILE NAME SPEC3.dwg

UG TRENCH
SHALLOW DEPTH
PRIMARY / SECONDARY

SCALE
NONE

DRAWING NUMBER
SPEC 3

Highlights

from the “Line Extension Policy” and Other New Service Info

All electric line extensions must be installed according to LPEA’s current “Line Extension Policy” and “Electric Service Regulations”. These documents are available online at <https://lpea.coop/policies> or copies will be provided upon request.

LPEA/CUSTOMER INSTALLED EQUIPMENT

LPEA shall install all equipment necessary to complete your service requirements. This may include:

- Primary cable
- Transformers
- Secondary/service wire to point of metering
- Meter pedestal adjacent to the transformer
- Meter

Electric service will be provided to an Association-owned meter. Installation, ownership, and maintenance of the service wire from the meter to the load location are the responsibility of the Applicant. Law prohibits LPEA from performing work on the customer’s side of the disconnect switch, as well as the tampering of LPEA-owned facilities by others.

The customer’s installation must be inspected and green-tagged by the Colorado State Electrical Inspector in a manner visible to the LPEA representative before a meter will be installed.

TRENCHING AND BEDDING

All boring, trenching, bedding, and backfilling are to be provided by the customer without cost to LPEA and with provisions made for other utilities in accordance with their requirements. Please see the “Underground Trench and Bedding Specifications” included in this packet for more detail.

- In trenches of normal depth, electrical conduit will be placed at a minimum depth of thirty-six (36) inches and a maximum depth of forty-two (42) inches.
- In trenches of shallow depth, electrical conduit must be covered with red-dyed concrete (Flow-fill is not acceptable). Installation must be inspected by an LPEA representative.

Highlights

from the “Line Extension Policy” and Other New Service Info

- Warning tape is required at six (6) inches below final grade in all trenches.
- Conduits installed in roadways are to be backfilled and compacted in a manner consistent with road compaction requirements of the local governing body (state, county, city, town, etc.).
- No LPEA lines will be energized until warning tape is installed and the trench has been completely backfilled.

LOCATION OF EXISTING UNDERGROUND FACILITIES

State law requires location of all underground utilities present on your property prior to any digging. Locates are arranged by calling the Utility Notification Center of Colorado (UNCC) at (800) 922-1987 or 811.

RIGHTS-OF-WAY/EASEMENTS

LPEA requires easement for all new electric lines. Typical easement width is 20 feet. If it is necessary to cross another’s property to serve the customer, an LPEA easement is required from the other property owner.

Any special considerations of easements and/or permits must have LPEA approval.

Easements must be written, approved, signed and notarized before the job is released to construction. Any costs associated with the acquisition of right-of-way are the responsibility of the customer.

TREE TRIMMING

To increase safety, reduce outages, and prevent expensive damage, LPEA will periodically trim or remove vegetation from the electric line right-of-way.