

### Residential Relocation Work Order

Below is a checklist to assist you with your new construction project:

**In order to expedite the assignment of your job to a staking engineer, complete the following:**

- Property owner to complete and sign the "Application for Work Order" with accurate Service Address (assigned by the county)
- Pay the required Design Fee (Credit card payments are not accepted for New Construction) \$400 non-refundable
- Provide the most current and recorded copy of Warranty Deed. Name on Warranty Deed must match name on application for work order.

*Submit the above by mail or at the office in Durango or Pagosa Springs.*

Upon receipt of the above, the first available staking engineer will contact you to arrange an appointment to meet at the site to discuss your job. Please make sure property pins are in place or property boundaries are marked prior to this meeting. After the on-site meeting, the staking engineer will draw your job, compute the construction estimate, and contact you. (NOTE: The estimate you receive is good for 30 days.)

**Job will be released to construction for scheduling after you complete the following.**

- Sign and notarize necessary easements and contracts
- Pay construction estimate (credit card payments are not accepted)
- Contact LPEA at (970) 247-5786 and ask to speak with the Line Superintendent, in Durango (La Plata County) or Pagosa Springs (Archuleta County), to coordinate scheduling for construction before you start trenching or clearing right-of-way. Be sure to reference your LPEA Work Order Number when you call.
- Clear right-of-way as required.

For Underground Line Extensions

**Prior to digging trench, obtain:**

- Existing underground utility locations with the Utility Notification Center of Colorado at (800) 922-1987 or 811
- Any required excavation permits
- Verify that trench location will be within dedicated right-of-way
- Dig your trench. All trenching must be per LPEA specifications. **(A \$600 fee will be charged to the customer if LPEA construction crews show up at the job site and the trench is not ready or if trench does not meet NESC depth specifications.)**

Notify the LPEA Line Superintendent that you are ready for construction to proceed.

LPEA extends line and installs electrical facilities to metering point. **You are responsible for everything past the metering point.**

Contact Colorado State Electrical Inspector to inspect your service; [www.dora.state.co.us/electric](http://www.dora.state.co.us/electric)

Contact LPEA to have your meter installed after:

- Trench has been backfilled (if underground electrical facilities are installed)**
  - Your service has been inspected and green-tagged by the Colorado State Electrical Inspector
  - Call La Plata Electric at 970-247-5786 with permit # from Colorado Electrical Inspector.
- LPEA will energize line and meter.

LA PLATA ELECTRIC ASSOCIATION, INC.

Application for Work Order

Residential

Revised 09/22/2022

Property Owner: \_\_\_\_\_ Spouse: \_\_\_\_\_
SSN: \_\_\_\_\_ Spouse SSN: \_\_\_\_\_
Service Address: \_\_\_\_\_ City: \_\_\_\_\_ Zip: \_\_\_\_\_
Subdivision: \_\_\_\_\_ Block: \_\_\_\_\_ Lot #: \_\_\_\_\_
Billing Address: \_\_\_\_\_ City/State: \_\_\_\_\_ Zip: \_\_\_\_\_
Home Phone: \_\_\_\_\_ Cell Phone: \_\_\_\_\_
Work Phone: \_\_\_\_\_ Email Address: \_\_\_\_\_
Service is: [ ] New [ ] Upgrade [ ] Relocation Project Contact: \_\_\_\_\_

The undersigned (hereinafter called the "Applicant") hereby applies for and agrees to purchase electric energy from the La Plata Electric Association, Inc. (hereinafter called the "Association") upon the following terms and condition:

- 1. The Applicant will comply with and be bound by the provisions of the Articles of Incorporation and Bylaws of the Association, and such rules, regulations, and policies as may periodically be adopted by the Board of Directors of the Association.
2. The Applicant agrees, when electric service is available to these premises, to pay the monthly charge in accordance with the applicable rate schedule. Applicant understands and agrees that the Association's responsibility does not extend beyond the point of the Applicant's ownership of the Applicant's service wires with the exception of the electric meter or pre-pay metering and associated equipment.
3. The Applicant hereby agrees to support and assist the Association in obtaining the right, privilege and easement to construct, operate and maintain the necessary electric facilities together with full right of ingress and egress, as may be necessary to extend and maintain this service. If the Association must purchase or condemn right-of-way, it will do so at the sole expense of the Applicant. The Applicant agrees it shall be solely responsible for the Association's actual expenses for: the acquisition, purchase or condemnation of right-of-way; surveying; special archaeological or environmental studies and permitting; the expenses associated with the construction of roads and reclamation of land damage. The Applicant shall pay to the Association such estimate of costs prior to the Association's commencement of construction. No portion of such payment of expenses is refundable to the Applicant. Any necessary subsequent costs related to permitting and/or renewals or extensions of rights-of-way shall be borne solely by the Applicant, his/her/its heirs, successors or assigns.
4. The Applicant hereby also grants the Association the right to cut and trim trees and shrubbery to the extent necessary to keep them clear of the electric facilities. All boring and trenching provided by the Applicant for the installation of the underground system must be located within the dedicated easements and the Applicant hereby warrants that the location of all required boring and trenching provided by the Applicant so conforms. Any boring and trenching found now, or in the future, outside of the dedicated easement will be relocated within the dedicated easements, and all costs for the relocation will be the responsibility of the Applicant.
5. Upon mutual acceptance, this application for electric service shall constitute a valid binding agreement between Applicant and the Association and shall continue in force until canceled by the Applicant with at least a twenty-four hour prior written notice, which must be received by the Association during regular office hours. This agreement may be terminated by the Association for any reason authorized by the Association's Bylaws or for a material breach of this agreement, including failure of the Applicant to comply with the rules, regulations and bylaws of the Association. The Applicant will remain liable for all charges incurred for electric service herein until the Association is advised of a change in the service.
6. The Applicant agrees to pay a deposit with the Association, such service security deposit as is required by the rules and regulations of the Association. The Applicant hereby grants and Association takes a security interest in said deposit as collateral for service to be applied by the Association, upon any non-payment, termination of service, insolvency, or petition for bankruptcy by undersigned Applicant. The Association shall apply said deposit to bills due the Association and refund any unused portion of deposit upon termination of electric service to the Applicant.
7. If this agreement is for the installation of new service it should be noted that, if this agreement is cancelled subsequent to design and engineering, but prior to construction and connection of new electric service, the Applicant shall be held liable for all costs incurred by the Association in the performance of such activities. It should be further noted that, new electric service and temporary construction service under this agreement are available without actual connection for only one (1) year, thus Applicant should plan to have permanent wiring completed and must request actual connection within that year, or this agreement will terminate and Applicant shall pay the Association for any outstanding service charges arising from this agreement.
8. The Association will schedule construction projects with the Applicant for a specific date upon request by the Applicant or their representative. Any cost overrun attributable to delays or changes caused by the Applicant or their representative will be the responsibility of the Applicant. If your trench will not be ready on the agreed date, you must notify the Association's construction supervisory personnel on or before 7a.m. of the agreed date. If the Association's construction crews show up and, for reasons attributable to a failure of the Applicant or their representative, cannot perform required construction, a \$600 fee will be charged to the Applicant.
9. Once the project construction is complete, the Association may reconcile actual costs incurred on the project against the original estimate. The Association reserves the right to provide a refund or collect additional costs.
10. Unless Applicant also signs the Disclaimer of Membership below, this Application shall constitute an application for membership in the Association. As a member of the Association, Applicant assumes no personal liability or responsibility for any debts or liabilities of the Association, and it is expressly understood that Applicant's private property cannot be attached for any such debts or liabilities of the Association. As a member of the Association, the Applicant agrees to comply with and be bound by the provisions of the Articles of Incorporation and Bylaws of the Association, as the same may periodically be lawfully amended. Each member of the Association, or in the case of a joint membership, the holders thereof jointly, or any one of them, but not all, shall be entitled to one (1) vote and no more upon each matter submitted to a vote of the Association's members.

Property Owner

Date: \_\_\_\_\_

ROUND UP AUTHORIZATION (OPTIONAL)

Yes, I wish to help our communities by rounding up my electric bill.

DISCLAIMER OF MEMBERSHIP (OPTIONAL)

The undersigned hereby chooses not to become a member of La Plata Electric Association, Inc.

As a customer of the Association, the Applicant agrees to comply with and be bound by the provisions of the Articles of Incorporation and Bylaws, as the same may periodically be lawfully amended.

Primary Applicant

Applicant

Date: \_\_\_\_\_

Applicant

## CLEAN SOIL

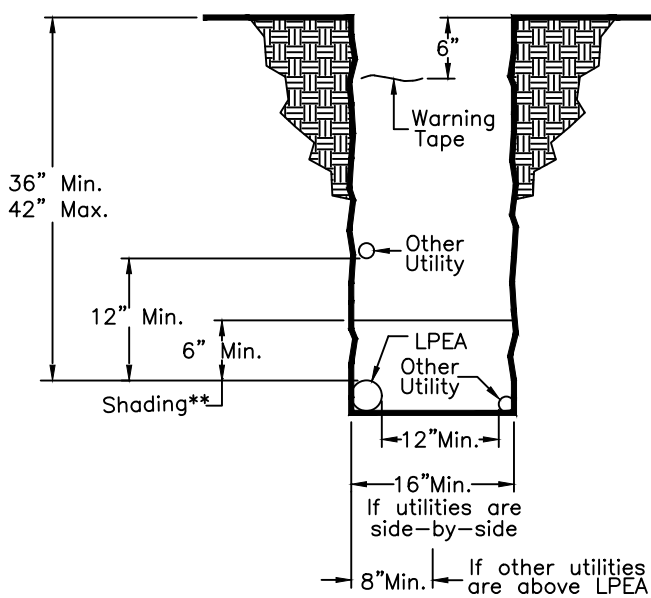

## ROCKY SOIL

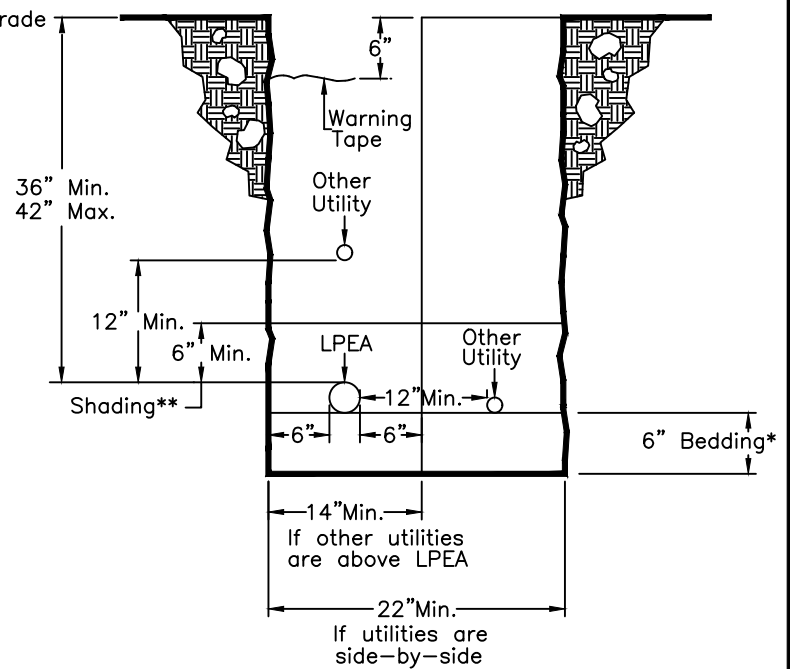

## SOLID ROCK

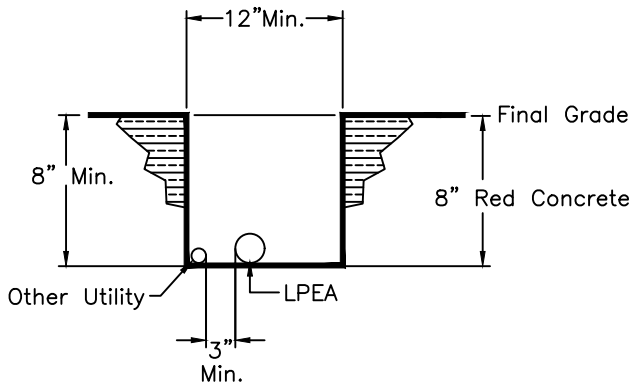

## IRRIGATION DITCH

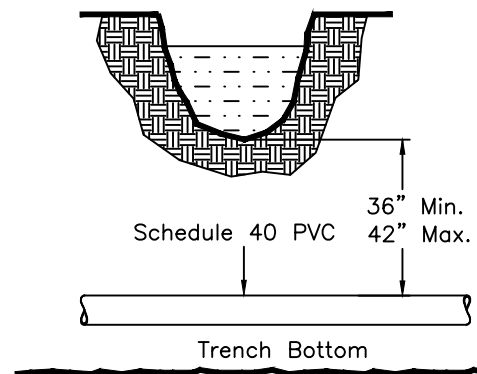

**NOTES:**

- 3" GREY SCHEDULE 40 PVC SLEEVE REQUIRED ON ALL SINGLE PHASE ROAD CUTS.
- 6" GREY SCHEDULE 40 PVC SLEEVE REQUIRED ON ALL THREE PHASE ROAD CUTS.
- 6" HDPE PIPE WILL BE UTILIZED FOR ALL BORES

WARNING TAPE SUPPLIED BY LPEA; INSTALLED BY CUSTOMER.

- \* BEDDING (ROCK FREE DIRT OR SAND) TO BE SUPPLIED AND INSTALLED BY CUSTOMER.
- \*\* SHADING (ROCK FREE DIRT OR SAND) TO BE SUPPLIED BY CUSTOMER; INSTALLED BY LPEA CREW. SHADING MUST BE SUPPLIED IN 20' INCREMENTS ALONG THE DITCH.

NO.	DATE	REVISIONS	APP'D

# LPEA

La Plata Electric Association, Inc.

A Touchstone Energy Cooperative 

PO Box 2750  
Durango CO 81302-2750  
COLORADO 32 LaPLATA

DRAWN  
JDD  
CHECKED  
APPROVED  
DATE  
06/26/08  
FILE NAME  
SPEC1.dwg

## UG TRENCH AND BEDDING SPECIFICATIONS PRIMARY

SCALE  
NONE

DRAWING NUMBER  
SPEC 1

### CLEAN SOIL

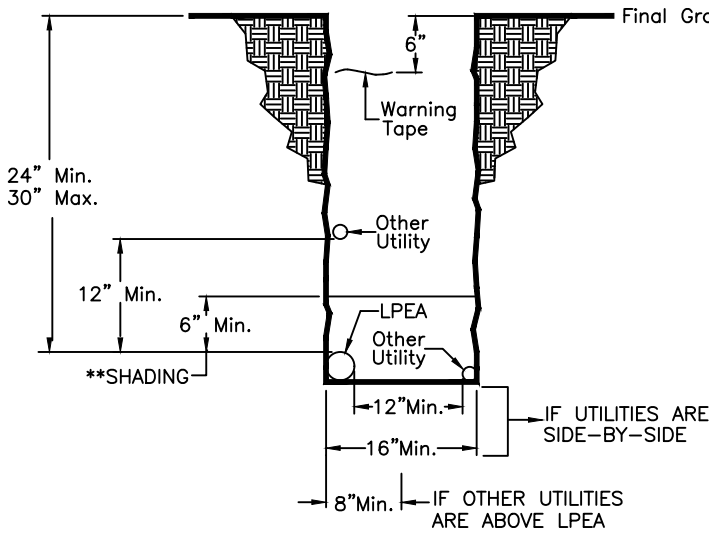

### ROCKY SOIL

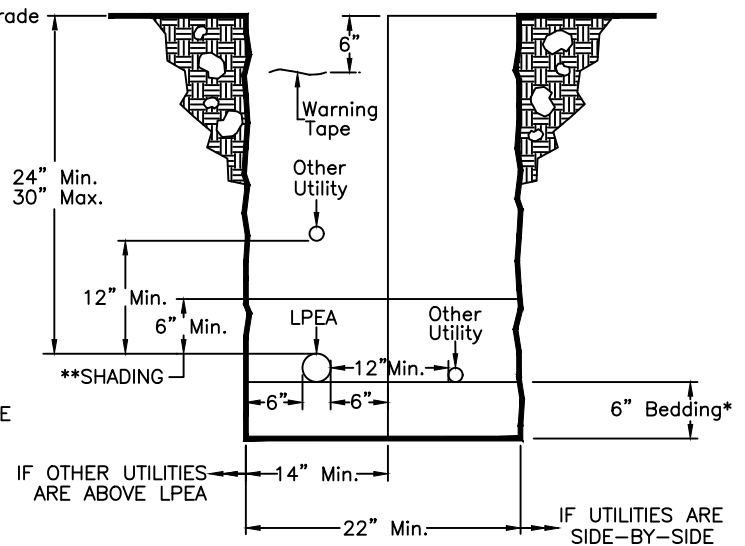

### SOLID ROCK

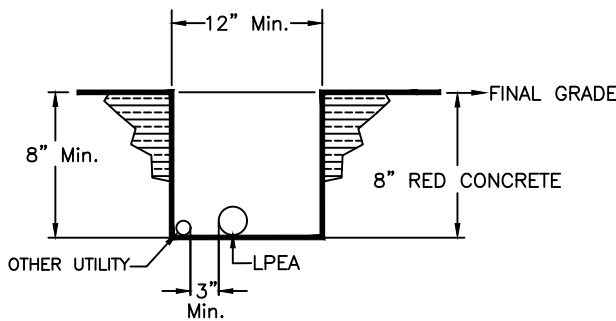

### IRRIGATION DITCH

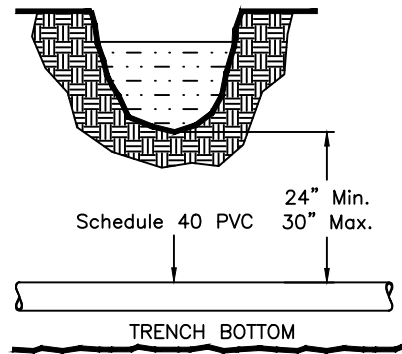

#### NOTES:

3" GREY SCHEDULE 40 PVC SLEEVE REQUIRED ON ALL SINGLE PHASE ROAD CUTS.

3" HDPE PIPE WILL BE UTILIZED FOR ALL SINGLE PHASE BORES

6" GREY SCHEDULE 40 PVC SLEEVE REQUIRED ON ALL THREE PHASE ROAD CUTS.

6" HDPE PIPE WILL BE UTILIZED FOR ALL THREE PHASE BORES

FLOW FILL NOT ACCEPTED.

WARNING TAPE SUPPLIED BY LPEA; INSTALLED BY CUSTOMER.

SERVICES 400 AMP OR GREATER REQUIRE CONSULTATION WITH A STAKING ENGINEER REGARDING SECONDARY REQUIREMENTS.

SERVICES GREATER THAN 800 AMP WILL REQUIRE PARALLEL RUNS OF CONDUIT OF ADEQUATE SIZE FOR THE REQUIRED CONDUCTOR. CUSTOMER MUST CONSULT WITH STAKING ENGINEER.

\* BEDDING (ROCK FREE DIRT OR SAND) TO BE SUPPLIED AND INSTALLED BY CUSTOMER.

\*\* SHADING (ROCK FREE DIRT OR SAND) TO BE SUPPLIED BY CUSTOMER; INSTALLED BY LPEA CREW.

\*\* SHADING MUST BE SUPPLIED IN 20' INCREMENTS ALONG THE DITCH.

NO.	DATE	REVISIONS	APP'D	DRAWN JDD	<b>UG TRENCH AND BEDDING SPECIFICATIONS</b>  <b>SECONDARY</b>	SCALE	DRAWING NUMBER
1	4/27/21	Removed suggested secondary wire type table	MAF	CHECKED		NONE	SPEC 2
2	4/27/21	Corrected HDPE sizes on bores	MAF	APPROVED			
3	4/27/21	Added required engineer consultation for services of 400 amps or greater.	MAF	DATE 06/26/08			
				FILE NAME SPEC2.dwg			

# LPEA

La Plata Electric Association, Inc.

A Touchstone Energy Cooperative 

PO Box 2750  
Durango CO 81302-2750  
COLORADO 32 LaPLATA

### 8" - 17" TRENCH DEPTH

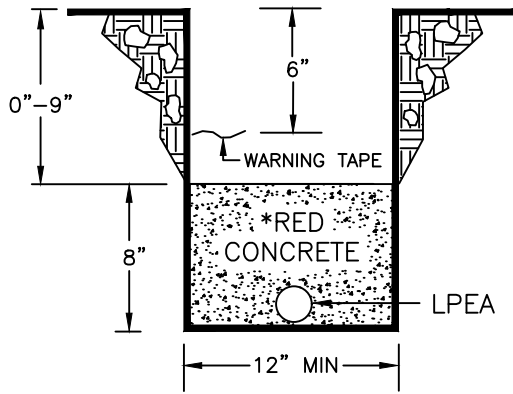

### 18" - 23" TRENCH DEPTH

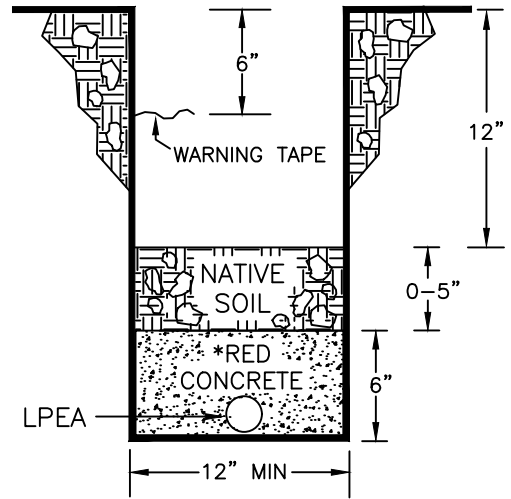

### 30"-35" TRENCH DEPTH

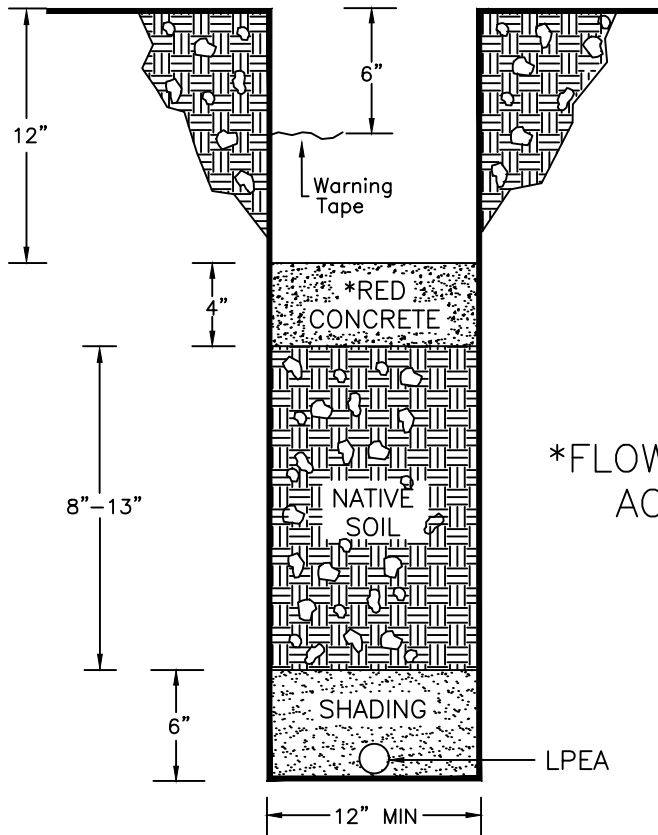

### 24"-29" TRENCH DEPTH

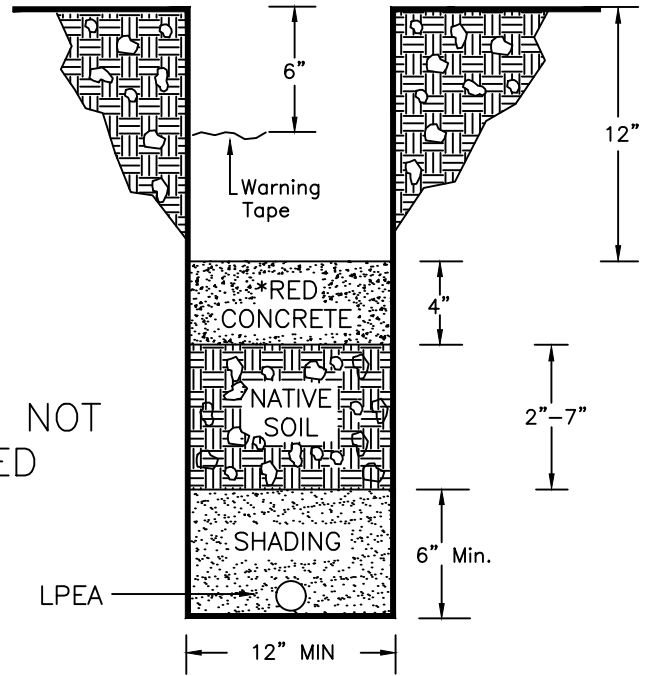

\*FLOW FILL NOT ACCEPTED

NO.	DATE	REVISIONS	APP'D

# LPEA

La Plata Electric Association, Inc.

A Touchstone Energy Cooperative

PO Box 2750  
Durango CO 81302-2750  
COLORADO 32 LaPLATA

DRAWN MF  
CHECKED  
APPROVED  
DATE 06/30/08  
FILE NAME SPEC3.dwg

UG TRENCH  
SHALLOW DEPTH  
PRIMARY / SECONDARY

SCALE  
NONE

DRAWING NUMBER  
SPEC 3

## Highlights

from the “Line Extension Policy” and Other New Service Info

*All electric line extensions must be installed according to LPEA’s current “Line Extension Policy” and “Electric Service Regulations”. These documents are available online at <https://lpea.coop/policies> or copies will be provided upon request.*

### LPEA/CUSTOMER INSTALLED EQUIPMENT

LPEA shall install all equipment necessary to complete your service requirements. This may include:

- Primary cable
- Transformers
- Secondary/service wire to point of metering
- Meter pedestal adjacent to the transformer
- Meter

Electric service will be provided to an Association-owned meter. Installation, ownership, and maintenance of the service wire from the meter to the load location are the responsibility of the Applicant. Law prohibits LPEA from performing work on the customer’s side of the disconnect switch, as well as the tampering of LPEA-owned facilities by others.

The customer’s installation must be inspected and green-tagged by the Colorado State Electrical Inspector in a manner visible to the LPEA representative before a meter will be installed.

### TRENCHING AND BEDDING

All boring, trenching, bedding, and backfilling are to be provided by the customer without cost to LPEA and with provisions made for other utilities in accordance with their requirements. Please see the “Underground Trench and Bedding Specifications” included in this packet for more detail.

- In trenches of normal depth, electrical conduit will be placed at a minimum depth of thirty-six (36) inches and a maximum depth of forty-two (42) inches.
- In trenches of shallow depth, electrical conduit must be covered with red-dyed concrete (Flow-fill is not acceptable). Installation must be inspected by an LPEA representative.

## **Highlights**

from the “Line Extension Policy” and Other New Service Info

- Warning tape is required at six (6) inches below final grade in all trenches.
- Conduits installed in roadways are to be backfilled and compacted in a manner consistent with road compaction requirements of the local governing body (state, county, city, town, etc.).
- No LPEA lines will be energized until warning tape is installed and the trench has been completely backfilled.

### **LOCATION OF EXISTING UNDERGROUND FACILITIES**

State law requires location of all underground utilities present on your property prior to any digging. Locates are arranged by calling the Utility Notification Center of Colorado (UNCC) at (800) 922-1987 or 811.

### **RIGHTS-OF-WAY/EASEMENTS**

LPEA requires easement for all new electric lines. Typical easement width is 20 feet. If it is necessary to cross another’s property to serve the customer, an LPEA easement is required from the other property owner.

Any special considerations of easements and/or permits must have LPEA approval.

Easements must be written, approved, signed and notarized before the job is released to construction. Any costs associated with the acquisition of right-of-way are the responsibility of the customer.

### **TREE TRIMMING**

To increase safety, reduce outages, and prevent expensive damage, LPEA will periodically trim or remove vegetation from the electric line right-of-way.