

New Construction Check List

Below is a checklist to assist you with your new construction project:

In order to expedite the assignment of your job to a staking engineer, complete the following:

- Complete and sign the "Application for Electric Service" with accurate Service Address
- Complete the "Load Data Sheet", which contains crucial information to ensure an appropriately designed electric service
- Pay the required Design Fee (Credit card payments are not accepted for New Construction)
- Pay the Service Deposit, if required (See the "Deposits" letter enclosed in this packet for your options)
- Provide copy of Warranty Deed

Upon receipt of the above, the first available staking engineer will contact you to arrange an appointment to meet at the site to discuss your job. Please make sure property pins are in place or property boundaries are marked prior to this meeting.

After the on-site meeting, the staking engineer will draw your job, compute the construction cost, and contact you.
(NOTE: The cost you receive is good for 30 days.)

Job will be released to construction for scheduling after the following are completed:

- Sign and notarize necessary easements and contracts
- Pay construction costs

Contact LPEA at (970) 247-5786 and ask to speak with the Line Superintendent, in Durango (La Plata County) or Pagosa Springs (Archuleta County), to coordinate scheduling for construction before you start trenching or clearing right-of-way. Be sure to reference your LPEA Work Order Number when you call.

Clear right-of-way as required.

For Underground Line Extensions

Prior to digging trench, obtain:

- Existing underground utility locations with the Utility Notification Center of Colorado at (800) 922-1987 or 811
- Any required excavation permits
- Verify that trench location will be within dedicated right-of-way

Dig your trench. All trenching must be per LPEA specifications. (A \$600 fee will be charged to the customer if LPEA construction crews show up at the job site and the trench is not ready.)

Notify the LPEA Line Superintendent that you are ready for construction to proceed.

LPEA extends line and installs electrical facilities to metering point. *You are responsible for everything past the metering point.*

Contact Colorado State Electrical Inspector to inspect your service;

(303) 869-3456 for La Plata County

(303) 869-3463 for Archuleta County

Contact LPEA to have your meter installed after:

- Trench has been backfilled (if underground electrical facilities are installed)
- Your service has been inspected and green-tagged by the Colorado State Electrical Inspector

LPEA energizes line and installs meter

If you have any questions or concerns, please feel free to contact us at any time.

LA PLATA ELECTRIC ASSOCIATION, INC.
Application for Electric Service & Membership Certificate

Revised 3/17/2020

Residential

Name: _____ Spouse: _____
 SSN: _____ Spouse SSN: _____
 Service Address: _____ City: _____
 Subdivision: _____ Block: _____ Lot: _____
 Billing Address: _____ City/State: _____ Zip: _____
 Home Phone: _____ Cell Phone: _____
 Work Phone: _____ Fax Number: _____
 Date Service Wanted: _____ Email Address: _____
 Previous Address: _____ City/State: _____ Zip: _____
 Place of Employment: _____
 Please indicate any type of life support system, if any: _____
 Applicant is: Property Owner Tenant Contractor
 Type of Dwelling: Apartment Condominium Single Family

The undersigned (hereinafter called the "Applicant") hereby applies for and agrees to purchase electric energy from the La Plata Electric Association, Inc. (hereinafter called the "Association") upon the following terms and condition:

- The Applicant will comply with and be bound by the provisions of the Articles of Incorporation and Bylaws of the Association, and such rules, regulations, and policies as may periodically be adopted by the Board of Directors of the Association.
- The Applicant agrees, when electric service is available to these premises, to pay the monthly charge in accordance with the applicable rate schedule. Applicant understands and agrees that the Association's responsibility does not extend beyond the point of the Applicant's ownership of the Applicant's service wires with the exception of the electric meter or pre-pay metering and associated equipment.
- The Applicant hereby agrees to support and assist the Association in obtaining the right, privilege and easement to construct, operate and maintain the necessary electric facilities together with full right of ingress and egress, as may be necessary to extend and maintain this service. If the Association must purchase or condemn right-of-way, it will do so at the sole expense of the Applicant. The Applicant agrees it shall be solely responsible for the Association's actual expenses for: the acquisition, purchase or condemnation of right-of-way; surveying; special archaeological or environmental studies and permitting; the expenses associated with the construction of roads and reclamation of land damage. The Applicant shall pay to the Association such estimate of costs prior to the Association's commencement of construction. No portion of such payment of expenses is refundable to the Applicant. Any necessary subsequent costs related to permitting and/or renewals or extensions of rights-of-way shall be borne solely by the Applicant, his/her/its heirs, successors or assigns.
- The Applicant hereby also grants the Association the right to cut and trim trees and shrubbery to the extent necessary to keep them clear of the electric facilities. All boring and trenching provided by the Applicant for the installation of the underground system must be located within the dedicated easements and the Applicant hereby warrants that the location of all required boring and trenching provided by the Applicant so conforms. Any boring and trenching found now, or in the future, outside of the dedicated easement will be relocated within the dedicated easements, and all costs for the relocation will be the responsibility of the Applicant.
- Upon mutual acceptance, this application for electric service shall constitute a valid binding agreement between Applicant and the Association and shall continue in force until canceled by the Applicant with at least a twenty-four hour prior written notice, which must be received by the Association during regular office hours. This agreement may be terminated by the Association for any reason authorized by the Association's Bylaws or for a material breach of this agreement, including failure of the Applicant to comply with the rules, regulations and bylaws of the Association. The Applicant will remain liable for all charges incurred for electric service herein until the Association is advised of a change in the service.
- The Applicant agrees to pay a deposit with the Association, such service security deposit as is required by the rules and regulations of the Association. The Applicant hereby grants and Association takes a security interest in said deposit as collateral for service to be applied by the Association, upon any non-payment, termination of service, insolvency, or petition for bankruptcy by undersigned Applicant. The Association shall apply said deposit to bills due the Association and refund any unused portion of deposit upon termination of electric service to the Applicant.
- If this agreement is for the installation of new service it should be noted that, if this agreement is cancelled subsequent to design and engineering, but prior to construction and connection of new electric service, the Applicant shall be held liable for all costs incurred by the Association in the performance of such activities. It should be further noted that, new electric service and temporary construction service under this agreement are available without actual connection for only one (1) year, thus Applicant should plan to have permanent wiring completed and must request actual connection within that year, or this agreement will terminate and Applicant shall pay the Association for any outstanding service charges arising from this agreement.
- The Association will schedule construction projects with the Applicant for a specific date upon request by the Applicant or their representative. Any cost overrun attributable to delays or changes caused by the Applicant or their representative will be the responsibility of the Applicant. If your trench will not be ready on the agreed date, you must notify the Association's construction supervisory personnel on or before 7a.m. of the agreed date. If the Association's construction crews show up and, for reasons attributable to a failure of the Applicant or their representative, cannot perform required construction, a \$600 fee will be charged to the Applicant.
- Unless Applicant also signs the Disclaimer of Membership below, this Application shall constitute an application for membership in the Association. As a member of the Association, Applicant assumes no personal liability or responsibility for any debts or liabilities of the Association, and it is expressly understood that Applicant's private property cannot be attached for any such debts or liabilities of the Association. As a member of the Association, the Applicant agrees to comply with and be bound by the provisions of the Articles of Incorporation and Bylaws of the Association, as the same may periodically be lawfully amended. Each member of the Association, or in the case of a joint membership, the holders thereof jointly, or any one of them, but not all, shall be entitled to one (1) vote and no more upon each matter submitted to a vote of the Association's members.

Owner/Officer
Date: _____

Applicant

Applicant

ROUND-UP AUTHORIZATION (OPTIONAL)

Yes, I wish to help our communities by rounding up my electric bill. Applicant Initials _____

DISCLAIMER OF MEMBERSHIP (OPTIONAL)

The undersigned hereby chooses not to become a member of La Plata Electric Association, Inc.

As a customer of the Association, the Applicant agrees to comply with and be bound by the provisions of the Articles of Incorporation and Bylaws, as the same may periodically be lawfully amended.

Primary Applicant
Date: _____

Applicant

Applicant

(OFFICE USE ONLY)

ACCOUNT #: _____	APPLICATION FEE: \$25.00	TO BE BILLED ON FIRST BILL
MEMBERSHIP #: _____	SERVICE CALL FEE: \$40.00	TO BE BILLED ON FIRST BILL
CAPITAL CREDIT #: _____	SERVICE DEPOSIT AMT: _____	SEE "DEPOSITS" LETTER
RATE CLASS: _____	DESIGN FEE: _____	DUE UPON APPLICATION
SERVICE ORDER #: _____	TEMPORARY CONNECT: _____	SEE "FEE SCHEDULE"
WORK ORDER #: _____	TOTAL CHARGES: _____	DUE UPON APPLICATION



Durango Office:
 P.O. Box 2750, Durango, CO 81302
 Phone: (970) 247-5786 Fax: (970) 247-2674
 Pagosa Springs Office:
 P.O. Box 305, Pagosa Springs, CO 81147
 Phone: (970) 247-5786 Fax: (970) 264-4327

Single-Family Residential Load Data Sheet

Service Location: _____ City: _____
 Member: _____ Phone: _____
 Mailing Address: _____ City: _____ State: ____ Zip: _____
 Electrician/Contractor: _____ Phone: _____

1. Processing of this form will not be possible if information is incomplete.
2. Significant revision to information on this form may necessitate rescheduling of job.
3. Any costs incurred by changes to design caused by a change in service requirements after construction is started may be charged to the member.

DISTRIBUTIVE GENERATION

Renewables such as PV, Micro-Hydro, Wind _____ **Total Proposed Generation** _____ kW

ELECTRIC LOAD INFORMATION

Main Disconnect Size _____ Amps _____ Volts _____ Phase
 Residence Square Footage _____

Connected Load

Lighting @ .003 kW/Sq.Ft. _____ kW

Electric Appliances: (Please check all that apply) _____ kW

_____ Range _____ Water Heater
 _____ Oven
 _____ Dryer

Heating and Air Conditioning:

Electric Heat (Non-ETS) _____ kW
 Fixed Electric Spacer Heater(s) _____ kW
 Geothermal Motor(s) _____ kW
 Air Conditioning (1 Ton = ~3.5 kW) _____ kW

Other Load (i.e. Hot Tub/Spa, Well Pump, Sump Pump, Motors, Tank Heaters): _____ kW

Time- of- Use (TOU) Program: _____ kW

Electric Thermal Storage (ETS) Heater(s) kW + Total Water Heater kW

Total Connected Load _____ kW

Print Name _____

Signature _____ Date _____

**** DEPOSITS ****

*New Construction
Residential Electric Service*

Any new customer of La Plata Electric Association that has not had previous service with us within the past 12 (twelve) months for a term of one year is required to pay a deposit of up to \$250.00. Options to waive this deposit are listed below.

Alternatives to waive the deposit are as follows:

1. You may provide us with a letter of credit from a current or previous utility company showing the past 12 months' payment history.
2. You may request a credit report through our office. A nationwide credit agency provides this service, and only you can authorize the running of a credit report. It can be authorized over the phone or you may come into our office and apply in person. There is no charge for this service.
3. You may provide us with a referral letter from an assistance agency.

Your deposit will be held until 12 consecutive monthly bills have been paid in a timely manner. If acceptable credit has been established after one year from the permanent connect date of your service, the deposit (including interest) is either refunded as a credit on your account or returned as a check. The interest rate is subject to change the first of every year.

If a deposit is required, it will be billed on your first bill after the meter has been set.

If you have any questions, please feel free to call or write and we will be happy to help. We look forward to serving you in the future.

CLEAN SOIL

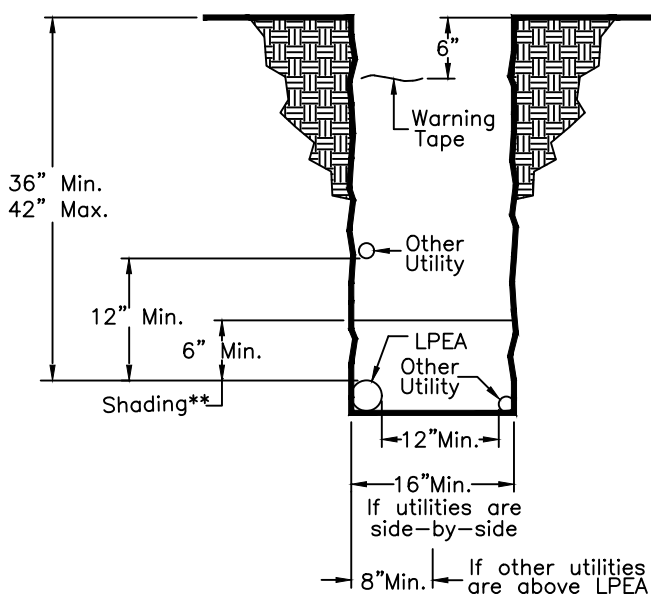

ROCKY SOIL

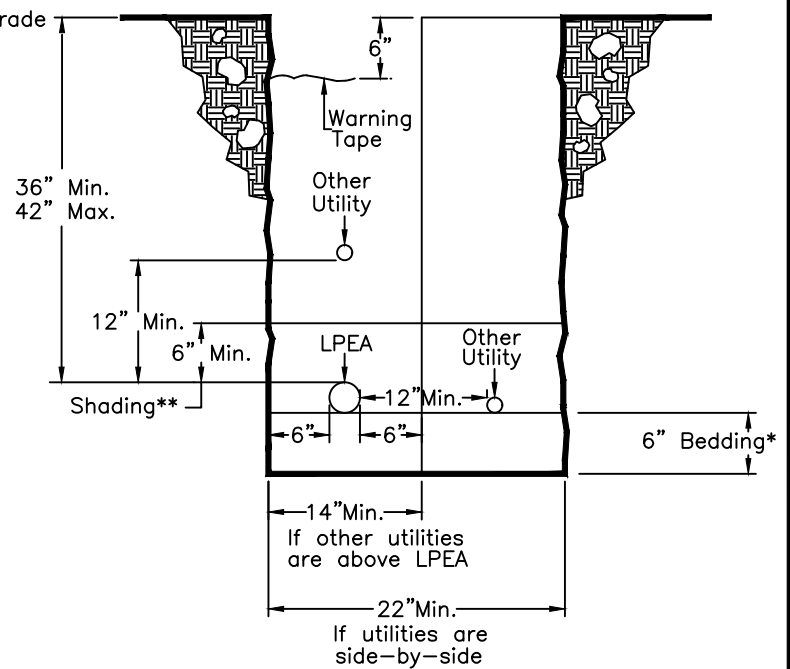

SOLID ROCK

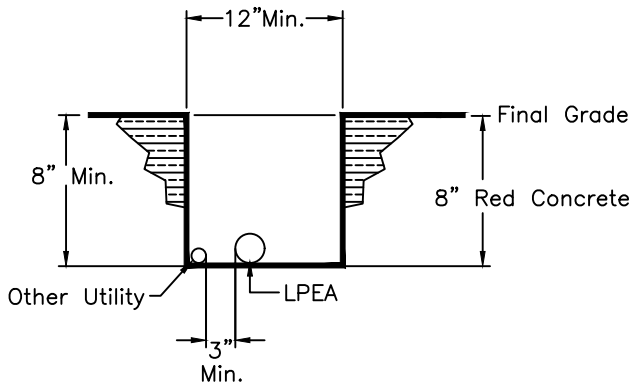

IRRIGATION DITCH

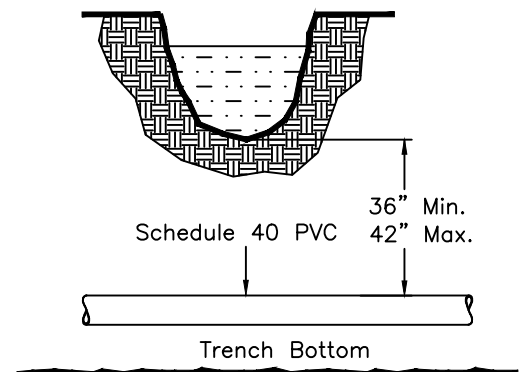

NOTES:

- 3" GREY SCHEDULE 40 PVC SLEEVE REQUIRED ON ALL SINGLE PHASE ROAD CUTS.
- 6" GREY SCHEDULE 40 PVC SLEEVE REQUIRED ON ALL THREE PHASE ROAD CUTS.
- 6" HDPE PIPE WILL BE UTILIZED FOR ALL BORES

WARNING TAPE SUPPLIED BY LPEA; INSTALLED BY CUSTOMER.

* BEDDING (ROCK FREE DIRT OR SAND) TO BE SUPPLIED AND INSTALLED BY CUSTOMER.

** SHADING (ROCK FREE DIRT OR SAND) TO BE SUPPLIED BY CUSTOMER; INSTALLED BY LPEA CREW. SHADING MUST BE SUPPLIED IN 20' INCREMENTS ALONG THE DITCH.

NO.	DATE	REVISIONS	APP'D

LPEA

La Plata Electric Association, Inc.

A Touchstone Energy Cooperative 

PO Box 2750
Durango CO 81302-2750
COLORADO 32 LaPLATA

DRAWN
JDD
CHECKED
APPROVED
DATE
06/26/08
FILE NAME
SPEC1.dwg

UG TRENCH AND BEDDING SPECIFICATIONS PRIMARY

SCALE
NONE

DRAWING NUMBER
SPEC 1

CLEAN SOIL

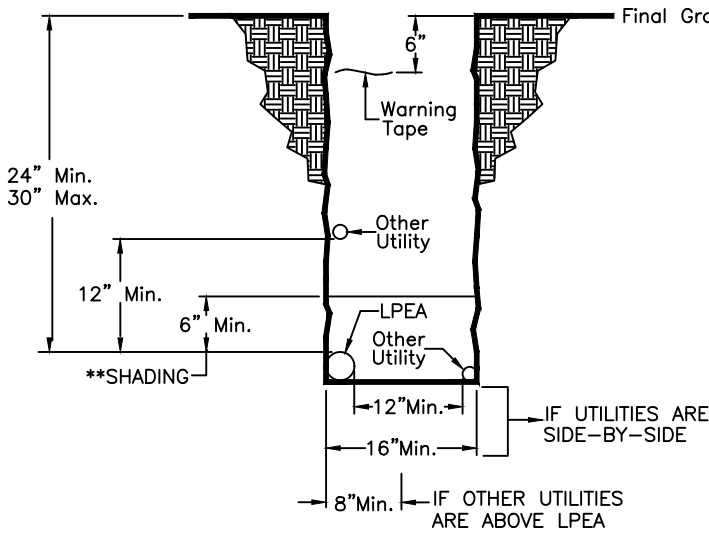

ROCKY SOIL

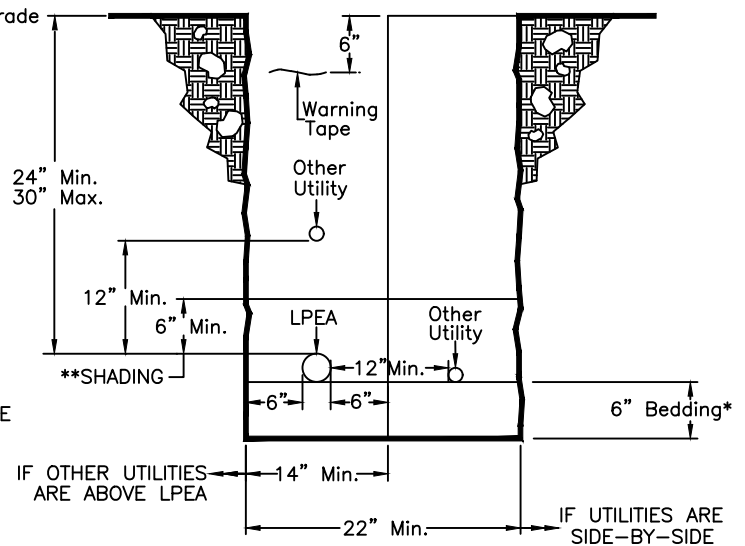

SOLID ROCK

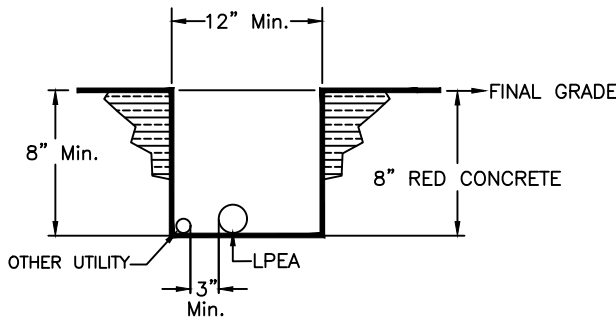

IRRIGATION DITCH

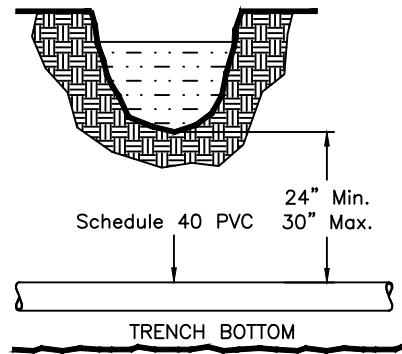

NOTES:

3" GREY SCHEDULE 40 PVC SLEEVE REQUIRED ON ALL SINGLE PHASE ROAD CUTS.

3" HDPE PIPE WILL BE UTILIZED FOR ALL SINGLE PHASE BORES

6" GREY SCHEDULE 40 PVC SLEEVE REQUIRED ON ALL THREE PHASE ROAD CUTS.

6" HDPE PIPE WILL BE UTILIZED FOR ALL THREE PHASE BORES

FLOW FILL NOT ACCEPTED.

WARNING TAPE SUPPLIED BY LPEA; INSTALLED BY CUSTOMER.



SERVICES 400 AMP OR GREATER REQUIRE CONSULTATION WITH A STAKING ENGINEER REGARDING SECONDARY REQUIREMENTS.

SERVICES GREATER THAN 800 AMP WILL REQUIRE PARALLEL RUNS OF CONDUIT OF ADEQUATE SIZE FOR THE REQUIRED CONDUCTOR. CUSTOMER MUST CONSULT WITH STAKING ENGINEER.

* BEDDING (ROCK FREE DIRT OR SAND) TO BE SUPPLIED AND INSTALLED BY CUSTOMER.

** SHADING (ROCK FREE DIRT OR SAND) TO BE SUPPLIED BY CUSTOMER; INSTALLED BY LPEA CREW.

** SHADING MUST BE SUPPLIED IN 20' INCREMENTS ALONG THE DITCH.

NO.	DATE	REVISIONS	APP'D	 <p>La Plata Electric Association, Inc. A Touchstone Energy Cooperative </p> <p>PO Box 2750 Durango CO 81302-2750 COLORADO 32 LaPLATA</p>	DRAWN JDD	UG TRENCH AND BEDDING SPECIFICATIONS SECONDARY	
1	4/27/21	Removed suggested secondary wire type table	MAF		CHECKED		
2	4/27/21	Corrected HDPE sizes on bores	MAF		APPROVED		
3	4/27/21	Added required engineer consultation for services of 400 amps or greater.	MAF		DATE 06/26/08	SCALE NONE	DRAWING NUMBER SPEC 2
					FILE NAME SPEC2.dwg		

8" - 17" TRENCH DEPTH

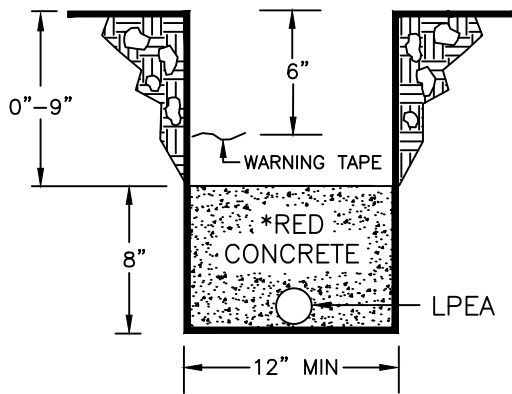

18" - 23" TRENCH DEPTH

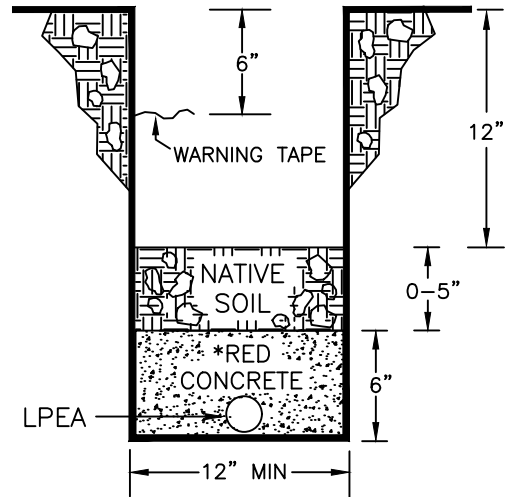

30"-35" TRENCH DEPTH

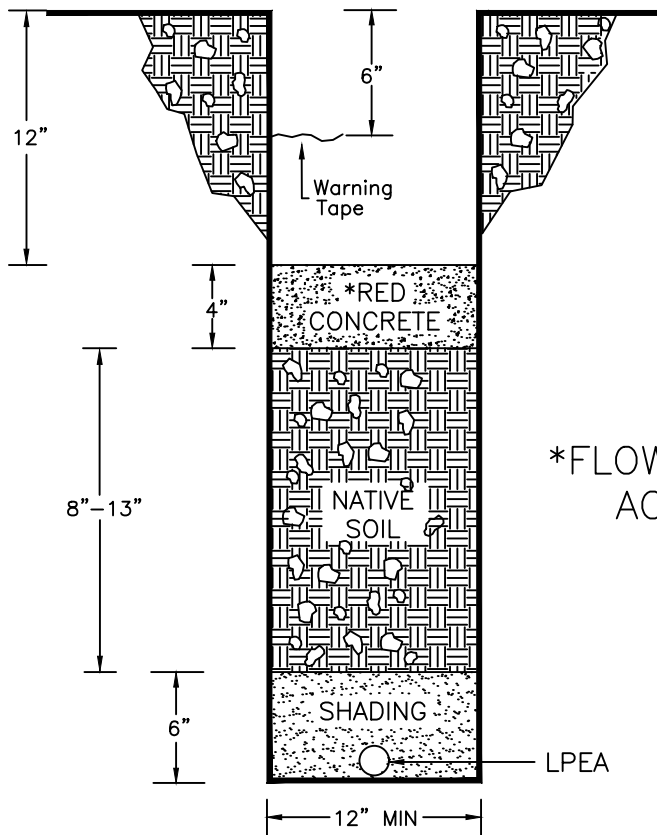

24"-29" TRENCH DEPTH

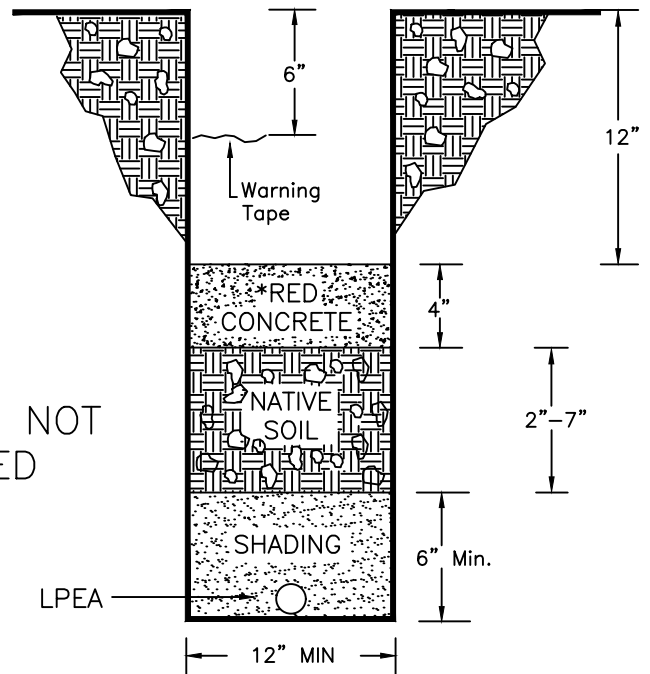

*FLOW FILL NOT ACCEPTED

NO.	DATE	REVISIONS	APP'D

LPEA

La Plata Electric Association, Inc.

A Touchstone Energy Cooperative

PO Box 2750
Durango CO 81302-2750
COLORADO 32 LaPLATA

DRAWN MF
CHECKED
APPROVED
DATE 06/30/08
FILE NAME SPEC3.dwg

UG TRENCH
SHALLOW DEPTH
PRIMARY / SECONDARY

SCALE
NONE

DRAWING NUMBER
SPEC 3

Highlights

from the “Line Extension Policy” and Other New Service Info

All electric line extensions must be installed according to LPEA’s current “Line Extension Policy” and “Electric Service Regulations”. These documents are available online at <https://lpea.coop/policies> or copies will be provided upon request.

LPEA/CUSTOMER INSTALLED EQUIPMENT

LPEA shall install all equipment necessary to complete your service requirements. This may include:

- Primary cable
- Transformers
- Secondary/service wire to point of metering
- Meter pedestal adjacent to the transformer
- Meter

Electric service will be provided to an Association-owned meter. Installation, ownership, and maintenance of the service wire from the meter to the load location are the responsibility of the Applicant. Law prohibits LPEA from performing work on the customer’s side of the disconnect switch, as well as the tampering of LPEA-owned facilities by others.

The customer’s installation must be inspected and green-tagged by the Colorado State Electrical Inspector in a manner visible to the LPEA representative before a meter will be installed.

TRENCHING AND BEDDING

All boring, trenching, bedding, and backfilling are to be provided by the customer without cost to LPEA and with provisions made for other utilities in accordance with their requirements. Please see the “Underground Trench and Bedding Specifications” included in this packet for more detail.

- In trenches of normal depth, electrical conduit will be placed at a minimum depth of thirty-six (36) inches and a maximum depth of forty-two (42) inches.
- In trenches of shallow depth, electrical conduit must be covered with red-dyed concrete (Flow-fill is not acceptable). Installation must be inspected by an LPEA representative.

Highlights

from the “Line Extension Policy” and Other New Service Info

- Warning tape is required at six (6) inches below final grade in all trenches.
- Conduits installed in roadways are to be backfilled and compacted in a manner consistent with road compaction requirements of the local governing body (state, county, city, town, etc.).
- No LPEA lines will be energized until warning tape is installed and the trench has been completely backfilled.

LOCATION OF EXISTING UNDERGROUND FACILITIES

State law requires location of all underground utilities present on your property prior to any digging. Locates are arranged by calling the Utility Notification Center of Colorado (UNCC) at (800) 922-1987.

RIGHTS-OF-WAY/EASEMENTS

LPEA requires easement for all new electric lines. Typical easement width is 20 feet. If it is necessary to cross another’s property to serve the customer, an LPEA easement is required from the other property owner.

Any special considerations of easements and/or permits must have LPEA approval.

Easements must be written, approved, signed and notarized before the job is released to construction. Any costs associated with the acquisition of right-of-way are the responsibility of the customer.

TREE TRIMMING

To increase safety, reduce outages, and prevent expensive damage, LPEA will periodically trim or remove vegetation from the electric line right-of-way.

LPEA's Time-of-Use Program can put time on your side! Save energy and dollars by shifting electricity usage to off-peak hours.

How does the Time-of-Use Program work?

To participate in Time-of-Use, sign up for special billing and receive a much lower rate for using electricity during off-peak hours. The more electricity usage you shift to off-peak hours, the more energy and dollars you save.

What are the rates and time periods?

- Off-peak rate: 5.9¢ per kilowatt-hour, Monday – Saturday, 10 p.m.-6 a.m. and 9 a.m.-5 p.m.; all day Sunday; plus Thanksgiving and Christmas
- On-peak rate: 23¢ per kilowatt-hour
- Base Charge per month: \$20

[The regular residential rate is 12.56¢ per kilowatt-hour with a \$21.50 Base Charge.]

Keys to saving with the TOLL program:

- Install timers on your large power consumers (electric water heaters, electric thermal storage units, etc.), ensuring they run during off-peak hours.
- Do the following during off-peak hours:
 - Run your dishwasher
 - Wash and dry clothes
 - Run self-cleaning oven cycle
- Install programmable thermostats to automatically control space heat; load control equipment; timers on stock tank heaters; and timers on heat tape.

We're happy to help make Time-of-Use work for you - and there's no cost to switch! Give us a call with any questions.

LPEA

La Plata Electric Association, Inc.

A Touchstone Energy® Cooperative 









The Heart of Your Power

www.lpea.coop
970.247.5786

Energy Efficiency Credit/Rebate Program

RESIDENTIAL

<p> LED LIGHT BULB</p>	<ul style="list-style-type: none"> - Up to \$8 per LED bulb purchased, not to exceed 50% of material costs (limit 50 - one submission per calendar year.) Visit www.lpea.coop for further details and application. Lumen output of 500 or greater
<p> ETS HEATER/THERMAL SLAB Controlled resistance</p>	<ul style="list-style-type: none"> - \$30/kW for Electric Thermal Storage (ETS) heater - \$30/kW for thermal slab heating system installation
<p> WATER HEATER/HEAT PUMP WATER HEATER</p>	<ul style="list-style-type: none"> - \$75 for Marathons or water heaters with lifetime tank warranty - \$55 for all other brands - \$350 for heat pump water heaters - 30-gallon minimum
<p> ENERGY STAR® APPLIANCES</p>	<ul style="list-style-type: none"> - \$20 per unit for new Energy Star rated dishwasher - \$30 per unit for new Energy Star rated refrigerator, freezer, clothes dryer and clothes washer - \$60 Refrigerator/Freezer Recycling <p>To verify that a specific model qualifies, visit www.energystar.gov</p>
<p> HEAT PUMP HVAC</p>	<ul style="list-style-type: none"> - Ground Source \$500/ton - Air Source \$300/ton 15-17 Seer, \$450/ton above 17 Seer - \$85 terminal unit
<p> ENERGY STAR® AIR CONDITIONERS SPLIT SYSTEM</p>	<ul style="list-style-type: none"> - \$150/unit, above 16 Seasonal energy efficiency ratio (Seer) - \$100/unit, 15 Seer to 16 Seer

LPEA recommends that customers request a walk-through energy assessment on homes where electricity is the primary heating system.



LPEA and its power supplier Tri-State Generation and Transmission will pay credits to their consumers for the aforementioned electric heating systems, and energy efficient products and programs. All credit must be requested within 120 days of installation. For detailed information go to: http://www.lpea.coop/programs_services/efficiencycredits.htm. Contact LPEA for more information at 970.247.5786

Whole House Surge Suppression

Benefit from protection provided by a *Sycom* whole-house, meter-based surge protector. This device plugs in under your electric meter and is designed to protect appliances not protected by a plug-in surge suppressor, such as washer/dryer, refrigerator and oven. We recommend using additional plug-in suppressors to protect sensitive electronics such as computers, televisions and satellite equipment.

An LPEA serviceman will install this device for you, and we will bill your account after installation.

The cost for an installed Sycom 200 Amp Meter-based suppressor is \$160.00.



Sycom SYC-240B
meter-based surge
protector

PREMIUM POWER SALE INFO

NAME _____ DATE _____

SERVICE ADDRESS _____

MAILING ADDRESS _____

CITY _____ STATE _____ ZIP _____

EQUIPMENT PURCHASES

QTY	INV#	MODEL	UNIT COST	TOTAL
1	10	Sycom 200A (initial install)/SYC-240B	\$160.00	\$160.00

SUBTOTAL: \$160.00

TAX: _____

TOTAL: **TO BE BILLED
ON FIRST BILL**

I authorize La Plata Electric Association, Inc. to charge my energy account number _____ for the above described equipment. I realize the billing for the equipment will begin with my next monthly bill. I agree to pay the above monthly payment plus my current monthly bill by the due date printed on the monthly bill. I understand that any partial payment will be applied to the installment payment first with any balance left applied to my current energy bill. I further understand that should I default on the installment agreement, LPEA will exercise its right to cure on or after the seventh day following the mailing of a notice of default to the address listed above.

CUSTOMER SIGNATURE

DATE

LPEA REPRESENTATIVE

DATE

Whole House Surge Suppression

Benefit from protection provided by a *M-Ti* whole-house, meter-based surge protector. This device plugs in under your electric meter and is designed to protect appliances not protected by a plug-in surge suppressor, such as washer/dryer, refrigerator and oven. We recommend using additional plug-in suppressors to protect sensitive electronics such as computers, televisions and satellite equipment.

An LPEA serviceman will install this device for you, and we will bill your account after installation.

The cost for an installed M-Ti CL320 Amp Meter-based suppressor is \$340.00.



*M-Ti CL320 Amp
meter-based
surge protector*



PREMIUM POWER SALE INFO

NAME _____ DATE _____
 SERVICE ADDRESS _____
 MAILING ADDRESS _____
 CITY _____ STATE _____ ZIP _____

EQUIPMENT PURCHASES

QTY	INV#	MODEL	UNIT COST	TOTAL
1	20	M-Ti CL320A (initial install)	\$340.00	\$340.00

SUBTOTAL: \$340.00

TAX: _____

TOTAL: **TO BE BILLED
ON FIRST BILL**

I authorize La Plata Electric Association, Inc. to charge my energy account number _____ for the above described equipment. I realize the billing for the equipment will begin with my next monthly bill. I agree to pay the above monthly payment plus my current monthly bill by the due date printed on the monthly bill. I understand that any partial payment will be applied to the installment payment first with any balance left applied to my current energy bill. I further understand that should I default on the installment agreement, LPEA will exercise its right to cure on or after the seventh day following the mailing of a notice of default to the address listed above.

 CUSTOMER SIGNATURE DATE LPEA REPRESENTATIVE DATE

A close-up photograph of a person's hand holding a structure made of pennies. The pennies are arranged to form the outline of a house, with the roof and walls visible. The background is a bright, sunny outdoor scene with a blue sky and green grass.

What goes around...

Pennies make a difference in our community – especially in tough economic times. Our area non-profit organizations and charitable agencies are seeing dramatic declines in their donations. This is where the La Plata Electric Round Up Foundation steps in to help.

The Round Up Foundation is a non-profit arm of your electric company, overseen by a volunteer board with representatives from all LPEA districts. Round Up is funded when our members opt to “round-up” their electric bills to the next higher dollar amount (an average of 50 ¢ per month). It may not seem like a lot, but collectively, those pennies add up, allowing Round Up to then offer grants to our very worthwhile community agencies supporting seniors, children, the homeless, the hungry and more.

Please sign up to add your pennies...

It all comes around to make our community stronger.



I understand a little bit will help a lot.

YES, please round up my electric bill.

All information remains confidential at La Plata Electric Association.

Name: _____

Electric service address or LPEA Account Number: _____

Phone Number: _____

Email address: _____



Please return this form to LPEA with your monthly payment or mail separately to LPEA, PO Box 2750, Durango, CO, 81302-2750 OR visit www.lpea.coop and sign up for Round Up Foundation on line.

