

New Construction Check List

Below is a checklist to assist you with your new construction project:

In order to expedite the assignment of your job to a staking engineer, complete the following:

- Complete and sign the "Application for Electric Service" with accurate Service Address
- Complete the "Load Data Sheet", which contains crucial information to ensure an appropriately designed electric service
- Pay the required Design Fee (Credit card payments are not accepted for New Construction)
- Pay the Service Deposit, if required (See the "Deposits" letter enclosed in this packet for your options)
- Provide copy of Warranty Deed

Upon receipt of the above, the first available staking engineer will contact you to arrange an appointment to meet at the site to discuss your job. Please make sure property pins are in place or property boundaries are marked prior to this meeting.

After the on-site meeting, the staking engineer will draw your job, compute the construction cost, and contact you.
(NOTE: The cost you receive is good for 30 days.)

Job will be released to construction for scheduling after the following are completed:

- Sign and notarize necessary easements and contracts
- Pay construction costs

Contact LPEA at (970) 247-5786 and ask to speak with the Line Superintendent, in Durango (La Plata County) or Pagosa Springs (Archuleta County), to coordinate scheduling for construction before you start trenching or clearing right-of-way. Be sure to reference your LPEA Work Order Number when you call.

Clear right-of-way as required.

For Underground Line Extensions

Prior to digging trench, obtain:

- Existing underground utility locations with the Utility Notification Center of Colorado at (800) 922-1987 or 811
- Any required excavation permits
- Verify that trench location will be within dedicated right-of-way

Dig your trench. All trenching must be per LPEA specifications. (A \$600 fee will be charged to the customer if LPEA construction crews show up at the job site and the trench is not ready.)

Notify the LPEA Line Superintendent that you are ready for construction to proceed.

LPEA extends line and installs electrical facilities to metering point. *You are responsible for everything past the metering point.*

Contact Colorado State Electrical Inspector to inspect your service;

- (303) 869-3456 for La Plata County
- (303) 869-3463 for Archuleta County

Contact LPEA to have your meter installed after:

- Trench has been backfilled (if underground electrical facilities are installed)
- Your service has been inspected and green-tagged by the Colorado State Electrical Inspector

LPEA energizes line and installs meter

If you have any questions or concerns, please feel free to contact us at any time.

**** DEPOSITS ****
New Construction
Commercial Electric Service

Commercial businesses new to La Plata Electric Association's system are required to pay a service deposit, which is intended to guarantee payment of monthly electric bills. The deposit amount is as follows:

- Commercial Up to \$500

Alternatives to waive the deposit are the following:

1. Businesses existing within LPEA's service area for 12 consecutive months or more, who are requesting new service for the same business or a like business, can have their LPEA credit history evaluated. This may or may not result in the deposit being waived.
2. An irrevocable letter of credit from a bank or a bond, effective for 12 months, may be provided to LPEA in lieu of a deposit.

Your deposit will be held until 12 consecutive monthly bills have been paid in a timely manner. If acceptable credit has been established after 12 months, the deposit (including interest) is refunded as a credit to your account or as a check. The interest rate is subject to change the first of every year.

If a deposit is required, it will be billed on your first bill after the meter is set.

If you have any questions, please feel free to call or write and we will be happy to help. We look forward to serving you in the future.

CLEAN SOIL

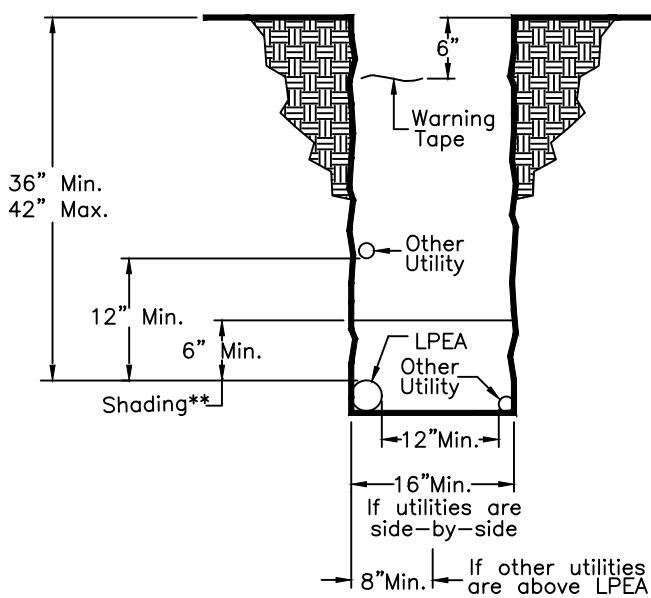

ROCKY SOIL

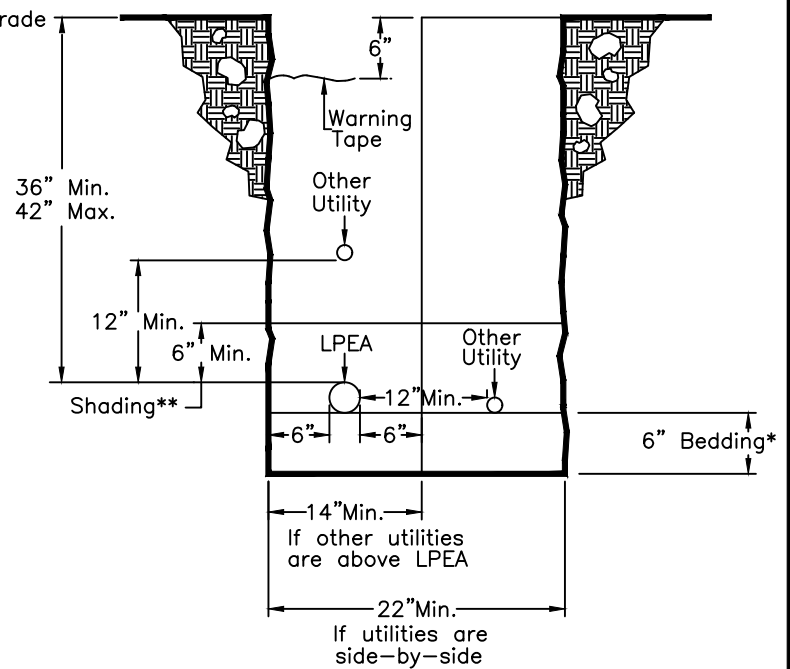

SOLID ROCK

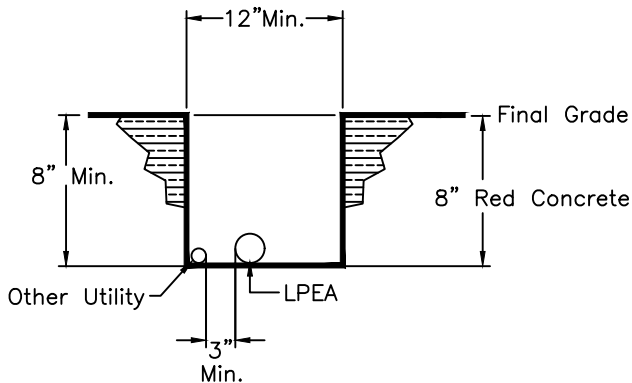

IRRIGATION DITCH

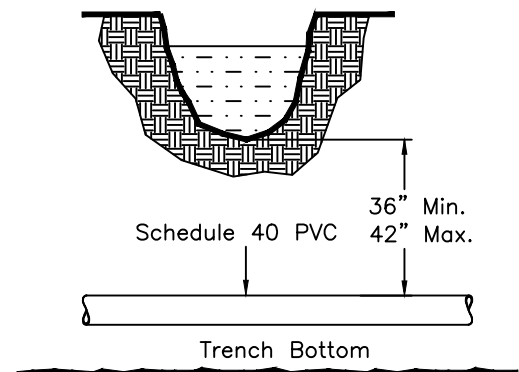

NOTES:

- 3" GREY SCHEDULE 40 PVC SLEEVE REQUIRED ON ALL SINGLE PHASE ROAD CUTS.
- 6" GREY SCHEDULE 40 PVC SLEEVE REQUIRED ON ALL THREE PHASE ROAD CUTS.
- 6" HDPE PIPE WILL BE UTILIZED FOR ALL BORES

WARNING TAPE SUPPLIED BY LPEA; INSTALLED BY CUSTOMER.

* BEDDING (ROCK FREE DIRT OR SAND) TO BE SUPPLIED AND INSTALLED BY CUSTOMER.

** SHADING (ROCK FREE DIRT OR SAND) TO BE SUPPLIED BY CUSTOMER; INSTALLED BY LPEA CREW. SHADING MUST BE SUPPLIED IN 20' INCREMENTS ALONG THE DITCH.

NO.	DATE	REVISIONS	APP'D

LPEA

La Plata Electric Association, Inc.

A Touchstone Energy Cooperative 

PO Box 2750
Durango CO 81302-2750
COLORADO 32 LaPLATA

DRAWN
JDD
CHECKED
APPROVED
DATE
06/26/08
FILE NAME
SPEC1.dwg

UG TRENCH AND BEDDING SPECIFICATIONS PRIMARY

SCALE
NONE

DRAWING NUMBER
SPEC 1

CLEAN SOIL

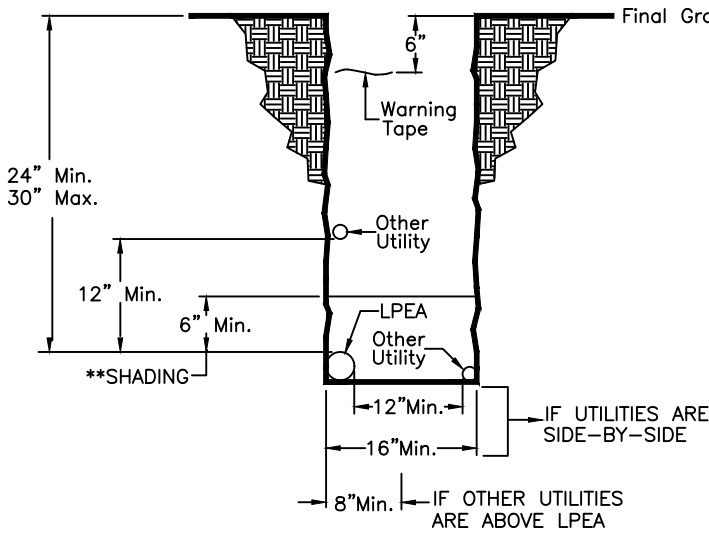

ROCKY SOIL

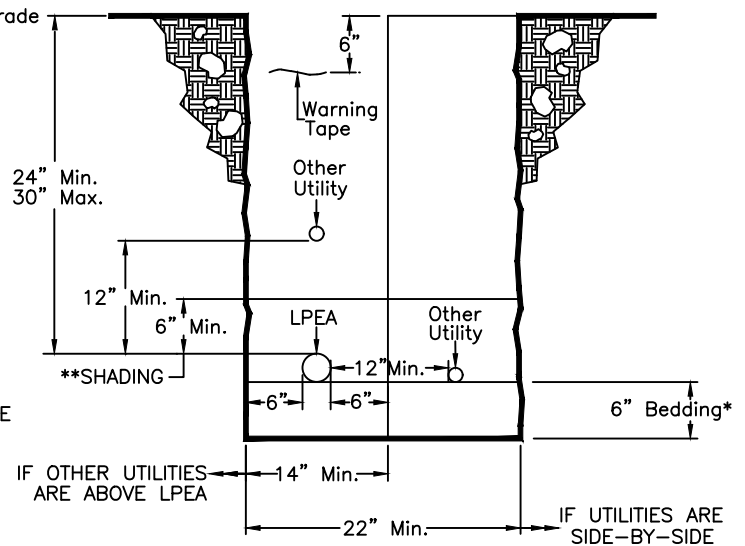

SOLID ROCK

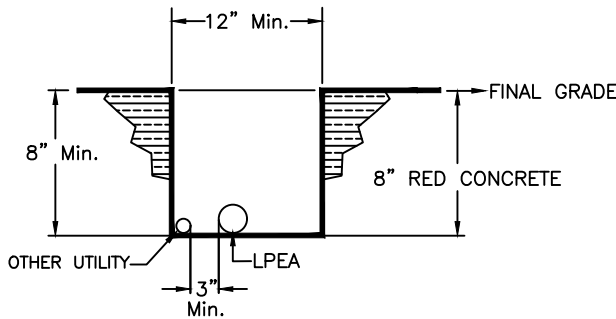

IRRIGATION DITCH

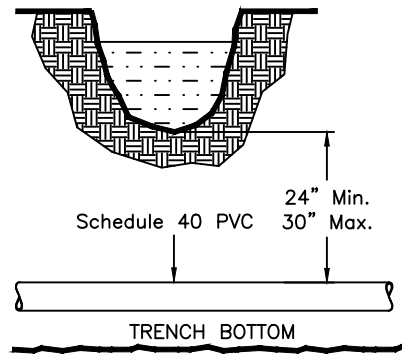

NOTES:

3" GREY SCHEDULE 40 PVC SLEEVE REQUIRED ON ALL SINGLE PHASE ROAD CUTS.

3" HDPE PIPE WILL BE UTILIZED FOR ALL SINGLE PHASE BORES

6" GREY SCHEDULE 40 PVC SLEEVE REQUIRED ON ALL THREE PHASE ROAD CUTS.

6" HDPE PIPE WILL BE UTILIZED FOR ALL THREE PHASE BORES

FLOW FILL NOT ACCEPTED.

WARNING TAPE SUPPLIED BY LPEA; INSTALLED BY CUSTOMER.



SERVICES 400 AMP OR GREATER REQUIRE CONSULTATION WITH A STAKING ENGINEER REGARDING SECONDARY REQUIREMENTS.

SERVICES GREATER THAN 800 AMP WILL REQUIRE PARALLEL RUNS OF CONDUIT OF ADEQUATE SIZE FOR THE REQUIRED CONDUCTOR. CUSTOMER MUST CONSULT WITH STAKING ENGINEER.

* BEDDING (ROCK FREE DIRT OR SAND) TO BE SUPPLIED AND INSTALLED BY CUSTOMER.

** SHADING (ROCK FREE DIRT OR SAND) TO BE SUPPLIED BY CUSTOMER; INSTALLED BY LPEA CREW.

** SHADING MUST BE SUPPLIED IN 20' INCREMENTS ALONG THE DITCH.

NO.	DATE	REVISIONS	APP'D	 <p>La Plata Electric Association, Inc. A Touchstone Energy Cooperative </p> <p>PO Box 2750 Durango CO 81302-2750 COLORADO 32 LaPLATA</p>	DRAWN JDD	UG TRENCH AND BEDDING SPECIFICATIONS SECONDARY	
1	4/27/21	Removed suggested secondary wire type table	MAF		CHECKED		
2	4/27/21	Corrected HDPE sizes on bores	MAF		APPROVED		
3	4/27/21	Added required engineer consultation for services of 400 amps or greater.	MAF		DATE 06/26/08	SCALE NONE	DRAWING NUMBER SPEC 2
					FILE NAME SPEC2.dwg		

8" - 17" TRENCH DEPTH

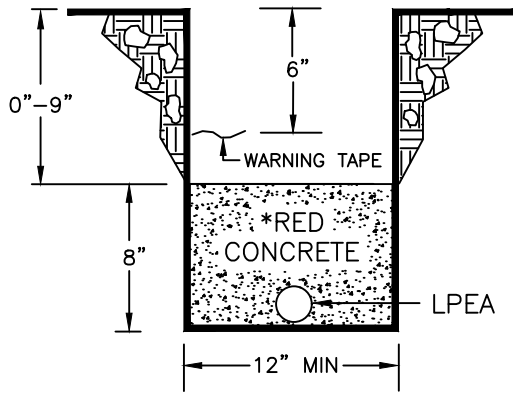

18" - 23" TRENCH DEPTH

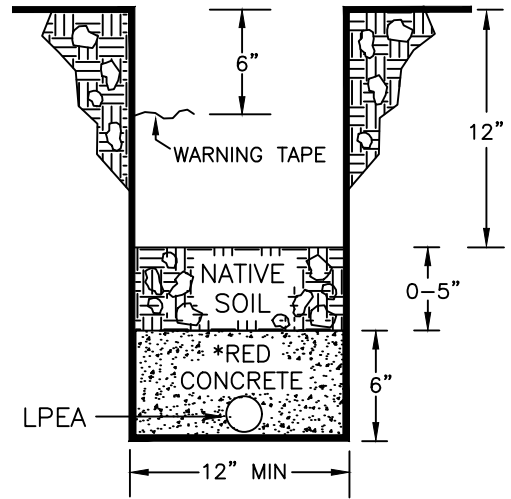

30"-35" TRENCH DEPTH

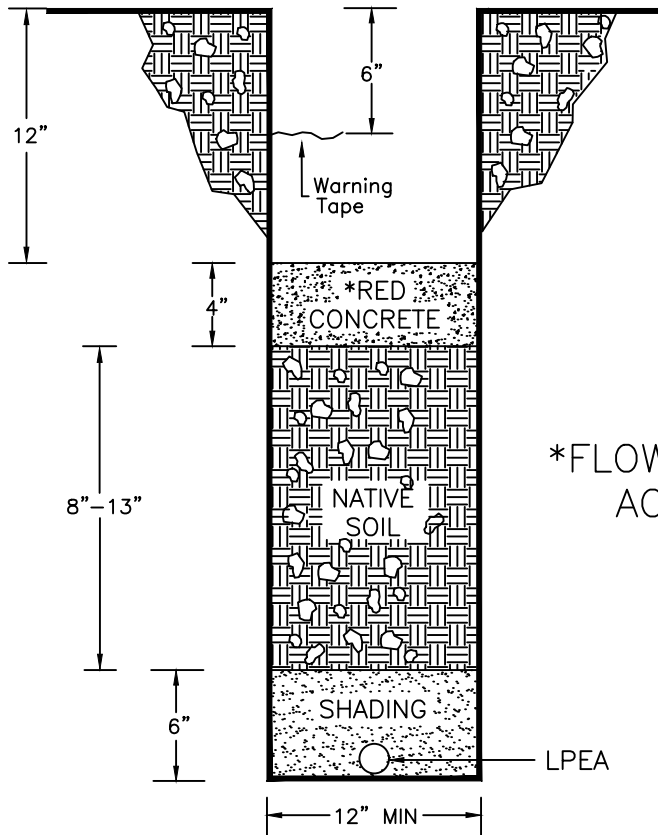

24"-29" TRENCH DEPTH

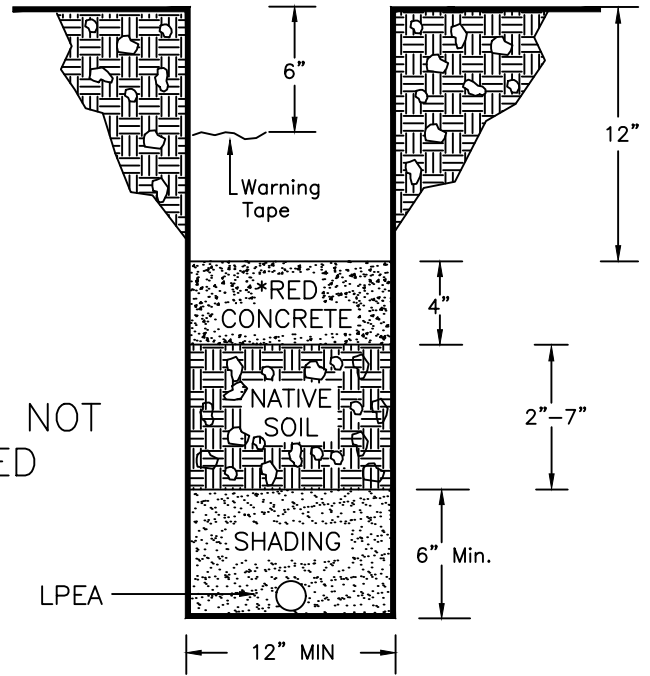

*FLOW FILL NOT ACCEPTED

NO.	DATE	REVISIONS	APP'D

LPEA

La Plata Electric Association, Inc.

A Touchstone Energy Cooperative

PO Box 2750
Durango CO 81302-2750
COLORADO 32 LaPLATA

DRAWN MF
CHECKED
APPROVED
DATE 06/30/08
FILE NAME SPEC3.dwg

UG TRENCH
SHALLOW DEPTH
PRIMARY / SECONDARY

SCALE
NONE

DRAWING NUMBER
SPEC 3

Highlights

from the "Line Extension Policy" and Other New Service Info

All electric line extensions must be installed according to LPEA's current "Line Extension Policy" and "Electric Service Regulations". These documents are available online at <https://lpea.coop/policies> or copies will be provided upon request.

DEVELOPER RESPONSIBILITIES

Prior to LPEA personnel staking the development, the developer shall:

- Provide an accurate plat of the development, including dedicated easements, to be used in design and cost estimating.
 - Preliminary plats may be used for early design and cost estimating; however, a hard copy of the final, recorded plat must be provided prior to preparation of contracts or the collection of contract money.
- Prior to staking of equipment locations, all lot corners and property lines must be identified, clearly marked and final grade must be established.

DEVELOPMENT DESIGN

LPEA staking personnel use the following guidelines in development design:

- Provision for electric service to all lots of the development will be made.
- Whenever practicable, LPEA equipment will be located at front lot corners and common to roadways, streets and alleys in order to provide access for installation, maintenance, replacement and/or removal of the equipment. The design shall, also, incorporate an equipment set-back of not less than ten (10) feet from the edge of the roadway or five (5) feet from the edge of the sidewalk to allow for snow removal and roadway maintenance.
- Forty-two (42) inches of clearance (a minimum of thirty-six (36) inches) must be maintained between sides and backs of LPEA primary equipment (i.e. pad mount transformers, junction boxes, switchgear) and all communication equipment. A minimum of ten (10) feet of clear space containing no obstructions is required in front of LPEA primary equipment.
- Whenever practicable, the design shall incorporate an alternate source of power to the development to allow for load switching, load balancing and a back-up source of power in case of equipment failure or failure caused by dig-in.

Highlights

from the "Line Extension Policy" and Other New Service Info

LPEA/CUSTOMER INSTALLED EQUIPMENT

LPEA shall install all equipment necessary to complete your service requirements. This may include:

- Primary cable
- Transformers
- Secondary/service wire to point of metering
- Meter pedestal adjacent to the transformer
- Meter

Electric service will be provided to an Association-owned meter. Installation, ownership, and maintenance of the service wire from the meter to the load location are the responsibility of the Applicant. Law prohibits LPEA from performing work on the customer's side of the disconnect switch, as well as the tampering of LPEA-owned facilities by others.

The customer's installation must be approved and tagged by the Colorado State Electrical Inspector in a manner visible to the LPEA representative before a meter will be installed.

TRENCHING AND BEDDING

All boring, trenching, bedding, and backfilling are to be provided by the customer without cost to LPEA and with provisions made for other utilities in accordance with their requirements. Please see the "Underground Trench and Bedding Specifications" included in this packet for more detail.

- In trenches of normal depth, electrical conduit will be placed at a minimum depth of thirty-six (36) inches and a maximum depth of forty-two (42) inches.
- In trenches of shallow depth, electrical conduit must be covered with red-dyed concrete (Flow-fill is not acceptable). Installation must be inspected by an LPEA representative.
- Warning tape is required at six (6) inches below final grade in all trenches.

Highlights

from the "Line Extension Policy" and Other New Service Info

- Conduits installed in roadways are to be backfilled and compacted in a manner consistent with road compaction requirements of the local governing body (state, county, city, town, etc.).
- No LPEA lines will be energized until warning tape is installed and the trench has been completely backfilled.

LOCATION OF EXISTING UNDERGROUND FACILITIES

State law requires location of all underground utilities present on your property prior to any digging. Locates are arranged by calling the Utility Notification Center of Colorado (UNCC) at (800) 922-1987.

RIGHTS-OF-WAY/EASEMENTS

LPEA requires easement for all new electric lines. Typical easement width is 20 feet. If it is necessary to cross another's property to serve the customer, an LPEA easement is required from the other property owner.

Any special considerations of easements and/or permits must have LPEA approval.

Easements must be written, approved, signed and notarized before the job is released to construction. Any costs associated with the acquisition of right-of-way are the responsibility of the customer.

TREE TRIMMING

To increase safety, reduce outages, and prevent expensive damage, LPEA will periodically trim or remove vegetation from the electric line right-of-way.